



# **Catalogue of Research Projects**

**of Tambov State  
Technical University**



2021



## Dear Colleagues and Friends,

Tambov State Technical University has recently overcome its 50th Anniversary of Tambov Institute of Chemical Engineering foundation. In the course of time Tambov Institute of Chemical Engineering has been developing and growing by many generations of teachers and scientists.

Tambov State Technical University is on the edge of the science: technosphere safety, information and nanotechnologies, bio-power engineering, new polymer and composite materials - the list of innovative research of TSTU is not completed. University scientific schools functioning in cooperation with the Russian Academy of Sciences and leading regional industrial enterprises solve the important problems of priority directions of science, technology and engineering development in the Russian Federation.



At present the University sets new goals:

- *creation and successful operation of research laboratories, centers of shared access, engineering centers and spinoff companies functioning in the frames of University development priority directions;*
- *dynamic development of the existing material and hardware potential for the implementation of competitive fundamental and applied research aimed at creation and realization of high-tech projects;*
- *training qualified specialists for high-tech production sector, civil and defense industries;*
- *TSTU integration into world research space.*

Achieving these goals means transformation of Tambov State Technical University to a multidisciplinary research and education center in the field of food, ecological, chemical, technosphere safety and sustainable development.

This ambitious character of new strategy demands a principally new approach to organization of training, research and international activity. So I hope, that the experienced university academic staff, qualified engineering personnel, active and creative students will put much efforts to achieve these new goals and help TSTU becoming one of the primary university for regional economy!

*Sincerely,  
Rector Mikhail Krasnyanskiy*

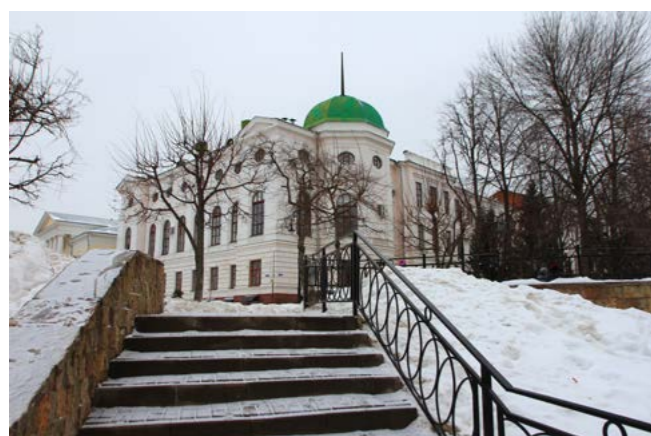



# Table of contents

## **Nanotechnologies and Nanomaterials**

Scientific and Methodological Fundamentals for Development of High-Techs and Innovative Equipment for Nanoproducts Manufacturing .....	<b>9</b>
Development of Technology and Equipment of Carbon Nanomaterials Processes for Application within Polymer Composites .....	<b>10</b>
Technology of Obtaining Nanotubes and Graphene Modified by Titanium Stearate .....	<b>11</b>
Technology of Obtaining Graphene Material Modified with Porous Carbon .....	<b>12</b>
Technology of Functionalization of Carbon Nanotubes and Graphene with Phenol-Formaldehyde Resins .....	<b>13</b>
Composite Materials for Sorbents, Solar Energy Converters, Supercapacitors and Chemical Sources of Current, Modified with Polyaniline .....	<b>14</b>
Technology and Equipment for Production of Few and Multilayer Graphene.....	<b>15</b>
Thermal Storage Heater Based on Nano-Modified Materials .....	<b>16</b>
Nanocarbon Additives for Construction Materials Modification .....	<b>17</b>
Multilayer Sorption Materials to Clean Water Medium from Radionuclides Based on Mineral Sorbents and Synthesized Carbon Nanomaterials .....	<b>18</b>
Functional Nanomaterials of Hyperfine Liquids Cleaning and Gases Aerosol Filtration.....	<b>19</b>
Multifunctional Polymer and Composite Materials Nanomodified with Carbon Nanotubes.....	<b>20</b>
Obtaining Nanomodified Galvanic and Electrochemical Coatings with Improved Quality Indicators .....	<b>21</b>
Development of Structure and Production Technology of Combustion Modifiers to Improve Detonation Resistance of Motor Gasolines .....	<b>22</b>

Synthesis of Ultrafine Oxides in Low-Temperature Plasma.....	<b>23</b>
--	-----------

## **Energy Efficiency and Energy Saving**

Oxygen-Enriched Air Production System.....	<b>25</b>
Concrete-Polymer Composites Modified by Introduction of Powdery and Industrial Wastes.....	<b>26</b>
Thermophysical Properties Test System for Salt-Permeated Wall Materials.....	<b>27</b>
Power-Technological Complex for Production of Granulated Biofuel with High Thermo-Technical Properties .....	<b>28</b>
Photobioreactor for Photosynthetic Microorganisms Cultivation.....	<b>29</b>
Contactless Methods and Device for Liquid Viscosity Control.....	<b>30</b>
Technology and Equipment for Obtaining Hydrodynamically Enhanced Structured Water.....	<b>31</b>
Methods and Devices for Quality Control and Diagnostics.....	<b>32</b>

## **Technologies of Food and Processing Industry**

Technology and Equipment for Complex Processing of Grain Materials.....	<b>34</b>
Development of Milk Whey Based Foodstuff for Dairy Milk Processing Plant .....	<b>35</b>
Technology of Functional Purpose Confectionery and Soft Drinks .....	<b>36</b>
Process of Cultivation of Microalgae <i>Chlorella Vulgaris</i> ИФП № C-111 Biomass with High Lipid Content .....	<b>37</b>

## **Environmental Science and Rational Nature Management**

Improvement of Roadway Covering Quality Using Recycled Polymer Materials with Road Binder Modification .....	<b>39</b>
--	-----------

Method of Predetermined Quality Water Treatment.....	40
Treatment of Altax Electrochemical Synthesis Wash Water by Electrical Baromembrane Methods .....	41
Membrane Technology for Solutions Separation of Galvanic Production Process Water.....	42
Development of Energy Efficient Technology and Equipment for Polymer Packages Waste Recycling.....	43
Evaluation of Noise Distribution through the Air Channels in Heating, Ventilation and Conditioning Systems While Designing Noise Reducing Devices .....	44

## Information Technologies

Optical System for Imaging of Structural and Functional Properties of Biological Tissue Surface.....	46
Computer Aided Measurement System for Properties Research and Calculation of Optimal Curing Modes of Polymer Materials .....	47
Automated Device “Artificial Lungs” for Human Respiratory Protection Equipment Testing.....	48
Intelligent Data-Measuring System for Nondestructive Testing of Thermo-Physical Properties of Solids.....	49
Computer-Aided Design System for Calculation of Operating and Design Parameters of Lathe Processing.....	50
Virtual Training Simulators for Industrial Process Operators.....	51
Regional Geo-Portal of Cultural and Historical Heritage .....	52
Automated Laboratory Unit for Research of Technological Scheme for New Chemicals Production.....	53
Virtual Room “Design of Technological Equipment” .....	54
Software Package for Calculation of Thermal Conductivity Coefficient of Building Materials Containing Hygroscopic Salts .....	55

Virtual Model Prototype of Chemical Technology University Hardware.....	56
Automated Information System «Children’s Health».....	57
Cardiovascular Hemodynamics Simulation System .....	58

## Mechanics and Mechanical Engineering

Use of Ordered Ingredients Loading for the Production of High-Grade Mixture of Bulk Materials.....	60
Screw Mixer with Paddle Working Bodies .....	61
High-Speed Planetary Mill .....	62
Ordered Mixing of Bulk Materials in Paddle Mixer .....	63
Device for Reduction of Diesel Engines Emissions Toxicity .....	64
Series of Automatically Adjustable Flow Dividers of Bulk Materials.....	65
Modeling of Intelligent Thin-Walled Constructions with Piezoelectric Sensors and Actuators Based on Geometrically Exact Finite Shell Elements .....	66

## SCIENTIFIC AND METHODOLOGICAL FUNDAMENTALS FOR DEVELOPMENT OF HIGH-TECHS AND INNOVATIVE EQUIPMENT FOR NANOPRODUCTS MANUFACTURING

### Designated purpose, application area.

The research results showed that unique properties of nanotubes have a wide application in science and industry, which significantly improve the characteristics of different materials and also contribute to new opportunities in various areas and a new range of productions. Nanomaterials are applied in electronics, aerospace, power engineering, chemical industry, automobile construction, medicine, construction, military industry.

### Originality, uniqueness.

Technologies of high quality carbonic nanomaterials synthesis series "TAUNIT", surpassing many foreign analogues, are designed and manufactured. Manufactured materials can be additionally adapted individually at the customer's request. Industrial reactor for carbonic nanomaterials synthesis is designed and manufactured, reactor capacity is 2000 kg/year

### Specifications.

Carbonic nanomaterials manufacturing is carried out by means of catalytic gas-core chemical vapor deposition. Carbonic nanostructured materials are manufactured with registered trademark "Taunit" (LtdLC "Nanotechcenter», Tambov). Products range

is various and consists of:

- Carbonic nanostructured material "Taunit" - Composition of UNT and UNVKS with external diameter 20-70 nm and length more than 2 msm.
- Multilayer carbonic nanotubes "Taunit-M":
- Coaxial carbonic nanotubes with external diameter 6-10 nm and length more than 2 msm;
- Multilayer carbonic nanotubes "Taunit-MD" - Coaxial carbonic nanotubes with external diameter 20-30 nm and length more than 20 msm.
- Multilayer carbonic nanotubes "Taunit-4": Coaxial carbonic nanotubes with external diameter 4-8 nm and length more than 50 msm.

# Nanotechnologies and Nanomaterials

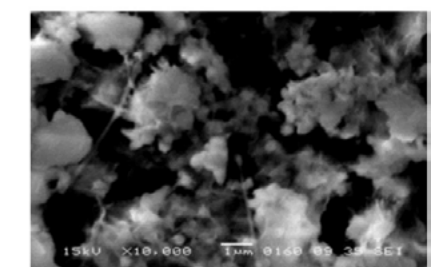
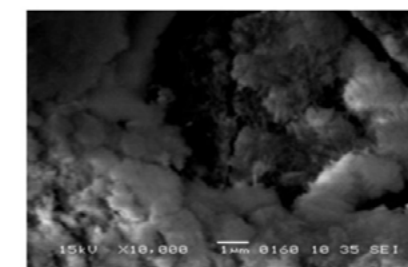
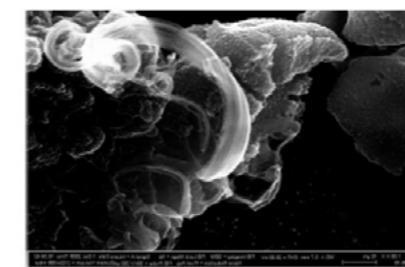
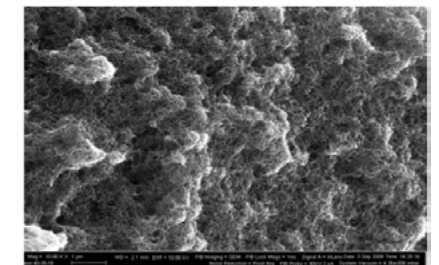
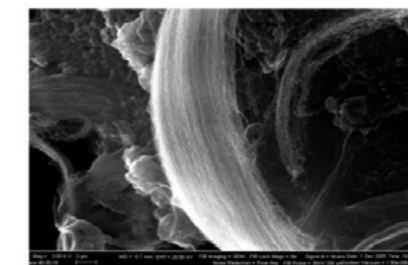
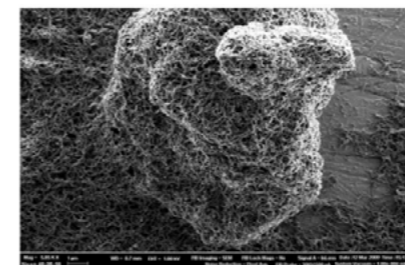

Chair "Technology and Methods of Nanoproducts Manufacturing"

Contact person: Doctor of Technical Sciences Rukhov Artyom Viktorovich

Tel.:+7 4752 63-92-93. E-mail: [postmaster@kma.tstu.ru](mailto:postmaster@kma.tstu.ru)



## DEVELOPMENT OF TECHNOLOGY AND EQUIPMENT OF CARBON NANOMATERIALS PROCESSES FOR APPLICATION WITHIN POLYMER COMPOSITES

### Designated purpose, application area.

Carbonic nanomaterials are effective modifiers of polymer composites with improved mechanical, radio shielding thermal and physical properties, thermal stability and aging resistance. The functionalization of the CNM surface provides chemical compatibility with the matrix and achieves higher quality indicators of listed properties at lower consumption rates.

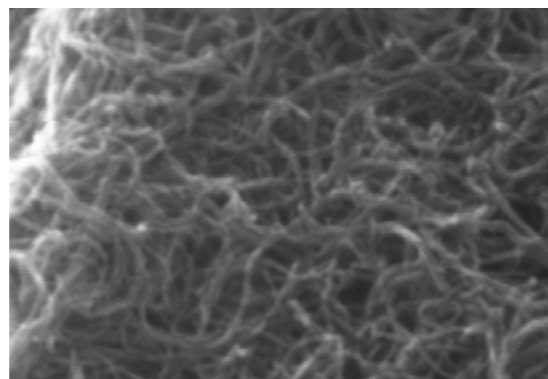

SEM-image of carboxylated CNT "Taunit-M"

containing groups. The destructive changes at surface of CNT decrease in the process of implementation. Each morphological type of CNT has specific operating conditions, they are determined by its features.

### Specifications.

Offered technologies allow producing 300 ... 500 kg of carbon nanomaterials functionalized forms of each type per year. Carboxylated and amidated CNT are characterized by a controlled content of functional groups up to 1 mmol/g. Functionalized CNM are offered in a dried form and in the form of aqueous and organic pastes containing up to 20 wt. % of CNT.

### Patent documentation:

- Patent RF №2529217 "Carbon Nanomaterials Functionalization Method". Authors: Dyachkova T.P., Melezhik A.V., Gorskiy S.Y., Rukhov A.V., Tkachev A.G

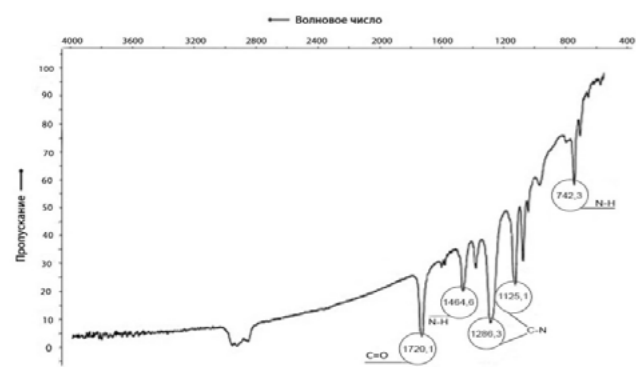

IR spectrum of amide CNT "Taunit-M"

Therefore, the high functionalized forms of CNM are in demand at the nanomodifiers market. But such materials are usually produced in laboratory. Development of industrial technologies for production of functional CNM is of great importance and demand. The list of technologies includes:

- production of carboxylated carbon nanotubes (CNT) with a given degree of functionalization by liquid phase oxidation;
- production of CNT with oxygen-containing functional groups of controlled composition through gas-phase oxidation;
- production of aminated and amidated CNT and nanofibers.

### Originality, uniqueness.

Functional methods are characterized by simple realization in industry and high ecological compatibility. It is possible to obtain broad range of functionalized CNT with controlled qualitative and quantitative structure of oxygen- and nitrogen-

Chair "Technology and Methods of Nanoproducts Manufacturing"

Contact person: Candidate of Chemical Sciences Dyachkova Tatyana Petrovna

Tel.: +7 4752 63-92-93. E-mail: postmaster@kma.tstu.ru

## TECHNOLOGY OF OBTAINING NANOTUBES AND GRAPHENE MODIFIED BY TITANIUM STEARATE

### Designated purpose, application area.

The use of titanium complexes with triethanolamine provides modification of carbon nanomaterials (CNM) by organotitanate water compounds.

CNM, modified by titanium stearate, are oleophilic and can be used as additives for non-polar polymers, oils.

### Originality, uniqueness.

The proposed project methods of functionalization and modification are eco-friendly and simple for realization in industry.

### Specifications.

The method of carbon nanomaterials modification by organotitanate water compounds is developed. Application of titanium complex with triethanolamine as a starting compound which is water soluble and fairly stable at alkaline pH. Thus, the problem of organotitanate compounds not resistant to water or not soluble was solved. This method is applicable for CNM and graphene. The process develops according to the scheme below.

Process implementation requires that the starting carbon nanomaterial (CNT or graphene) contains oxide groups at surface, where titanium stearate groups are attached. The developed technology is eco-

friendly, applied as reagent triethanolamine can be returned into the process cycle.

Weight content of CNT or graphene in a modified product is 40% with oil dispersibility.

### Patent documentation:

- Invention Application of the Russian Federation № 2012127991 "Modification Method of Carbon Nanotubes" for obtaining technochemical hydrophilic CNT is submitted. Authors: Tkachev A.G., Melezhik A.V., Dyachkova T.P., Aladinskiy A.A., submission date 03.07.2012, date of publication 01.20.2014
- Application for modifying of CNM with titanium stearate is submitted "Method of Carbon Nanomaterials Modification". Authors: Tkachev A.G., Melezhik A.V., Dyachkova T.P. The application was submitted to Rospatent, the priority date 06.18.2013, registration number 2013128040.

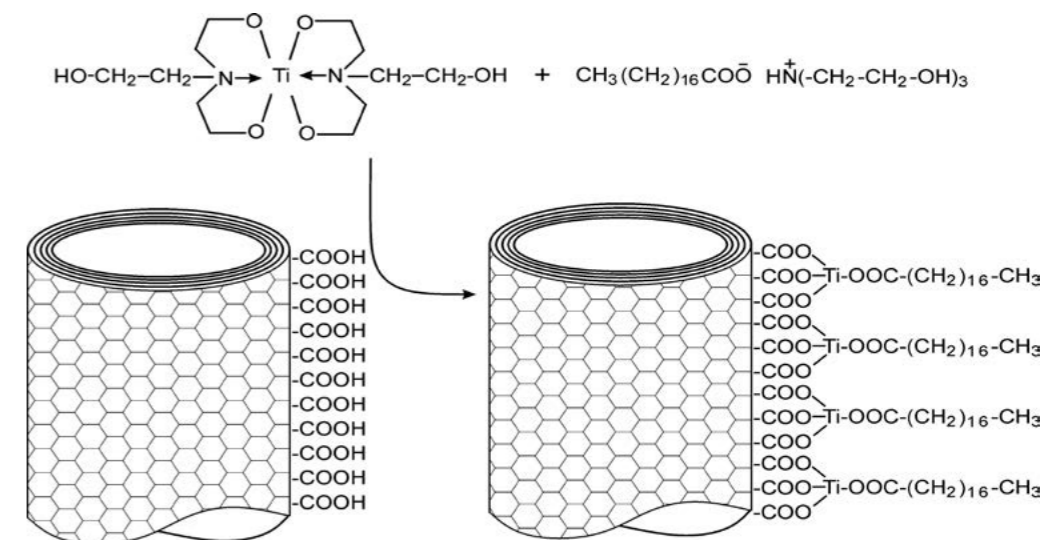

Chair "Technology and Methods of Nanoproducts Manufacturing"

Contact person: Candidate of Chemical Sciences Melezhik Aleksander Vasilyevich

Tel.: +7 4752 63-92-93. E-mail: postmaster@kma.tstu.ru

## TECHNOLOGY OF OBTAINING GRAPHENE MATERIAL MODIFIED WITH POROUS CARBON

### Designated purpose, application area.

Graphene material modified with porous carbon can be applied as electrode material of supercapacitors and also as adsorbent.

### Originality, uniqueness.

The proposed modification method is eco-friendly and simple for realization in industry.

Designed nanoporous carbon materials are perspective as a template for the synthesis of different nanocomposite materials.

### Specifications.

The technology includes the surface modification of graphene nanoplates with polymers followed by carbonization and alkaline activation.

- mass percent of graphene 10...20%;
- surface area 2500...3200 m<sup>2</sup>/g;
- pore volume 1,5...2,5 sm<sup>3</sup>/g;
- pore size in the range of 0,7...2,0 or 2...8 nm depending on activation method and material function.

For example, the picture shows the distribution of pores in a diameter range for one of the materials.



The size of pores control is provided by choice of initial reaction mixture structure and activation temperature. Thus, it is possible to obtain highly porous carbon materials designed for use in water environment and in organic electrolytes. The electrical capacity of materials, developed in an aqueous electrolyte, reaches 200 F/g, which is not inferior to the best-known carbon materials used in supercapacitors.

Choosing pore size and surface groups nature the selectivity of materials, developed to various substances, can also be achieved, if they are applied as adsorbents.

### Patent documentation:

- *Application RF №2013 128 041 "Method of Graphene Obtaining". Authors: Tkachev A.G., Melezhik A.V., submitted 18.06.13*

Chair "Technology and Methods of Nanoproducts Manufacturing"  
Contact person: Candidate of Chemical Sciences Melezhik Aleksander Vasilyevich  
Tel.: +7 4752 63-92-93. E-mail: postmaster@kma.tstu.ru

## TECHNOLOGY OF FUNCTIONALIZATION OF CARBON NANOTUBES AND GRAPHENE WITH PHENOL-FORMALDEHYDE RESINS

### Designated purpose, application area.

The carbon nanomaterial "Taunit" (CNT) and graphene, modified with phenol-formaldehyde resins are used:

- for obtaining stable water solutions of CNT and graphene by adding them to different water-based compositions;
- as starting materials for synthesis of nanocomposites with different structures, including aerogels;
- as starting materials for preparation of CNT compositions with epoxy- and phenol-formaldehyde resins.

### Specifications.

The technology includes phenolic oligomers chemisorption on the surface of carbon nanotubes or graphene. Carbon nanotubes and graphene nanoplates, modified by this method have water solubility 100 - 200 times more than the known analogues together with surfactants. The picture shows dependence of the solubility of the modified CNT from initial CNT in aqueous solution. The solubility reaches about 10 g/l at a very small mass of phenolic resin (0.25 wt. of resin to 1 wt. of CNT).

### Originality, uniqueness.

The proposed functionalization and modification methods are eco-friendly and simple for realization in industry.

CNT and graphene, modified by phenol-formaldehyde resin, may be used as components to obtain different composite materials. The picture shows film in a scanning electron microscope, obtained from the modified CNT Taunit M. There is no chaotic aggregation, typical for the initial CNT but ordered mutual orientation of the nanotubes at sufficiently long sections is achieved.

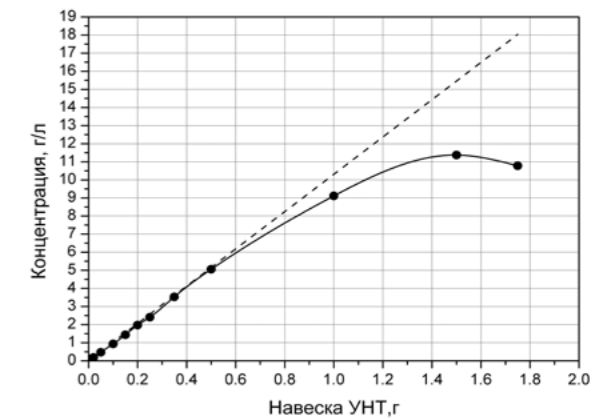

Solubility dependence of modified CNT and initial CNT in water solution

### Patent documentation:

- *Application for the Invention of the Russian Federation "Method of Carbon Nanomaterials Dispersions Production" for modifying of CNM by phenol-formaldehyde resins is submitted, date of submission January, 2015.*

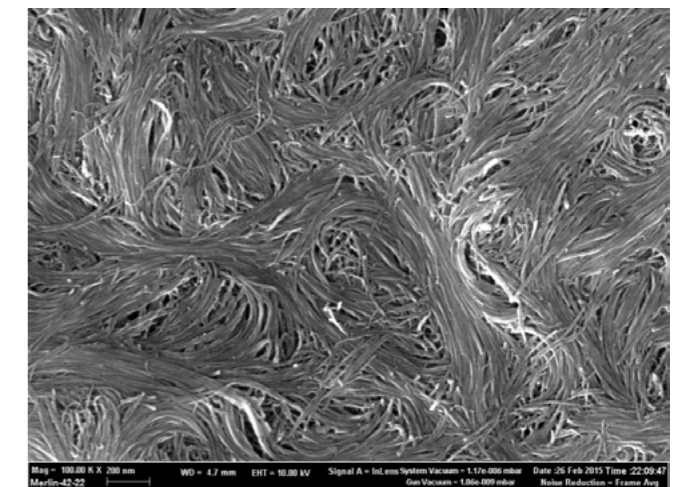

Chair "Technology and Methods of Nanoproducts Manufacturing"  
Contact person: Candidate of Chemical Sciences Melezhik Aleksander Vasilyevich  
Tel.: +7 4752 63-92-93. E-mail: postmaster@kma.tstu.ru



## COMPOSITE MATERIALS FOR SORBENTS, SOLAR ENERGY CONVERTERS, SUPERCAPACITORS AND CHEMICAL SOURCES OF CURRENT, MODIFIED WITH POLYANILINE

### Designated purpose, application area.

Nanocomposites based on nanocarbon dispersed carriers and electrically conductive polymers are perspective materials to be applied in different spheres. Since polyaniline adsorbs bacteria and viruses, effective adsorbents for water decontamination, biological fluids and medical bandaging material can be created.

Materials and coatings, absorbing electromagnetic radiation can be produced by combination of polyaniline with other organic and inorganic components. Anti-corrosion properties of polyaniline are noted.

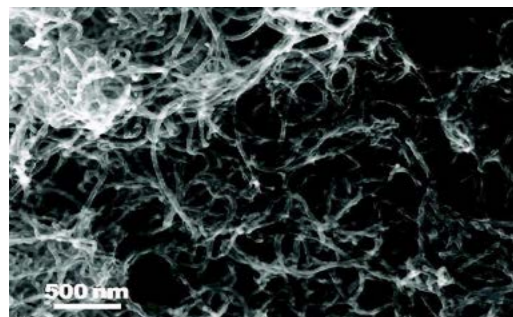

Composite PANI/Taunit-M

Polyaniline additives of polymer materials give such materials fire resistance. Nanostructured polyaniline materials are used as electrode materials in chemical power sources, photocatalysts, solar energy converters.

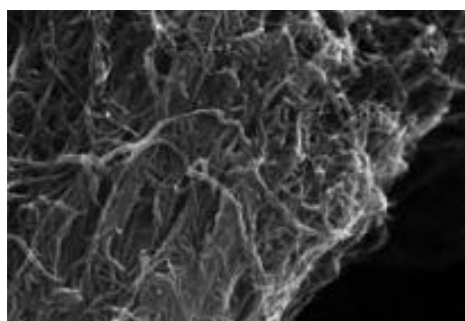

Composite PANI/Taunit-MD

Thus, nanostructured materials containing polyaniline, organic and mineral components can have a wide range of application, and, considering the low cost of starting materials, they are economically beneficial. At the same time it is possible to produce multi-functional materials, such as sorbent effective to remove ions of heavy metals, radionuclides, harmful organic compounds, viruses, bacteria from water.

### Originality, uniqueness.

Developed composites have improved electrochemical stability under repeated recharging for supercapacitors and chemical current sources.

**Specifications.** The specific electric capacity up to 500 F/g, keeping for at least 100 charge-discharge cycles. Specific surface area - 200 m<sup>2</sup>/g. Stable high electrical conductivity.

### Patent documentation:

- Patent RF № 2501602 "Complex Granular Nanosorbent".
- Application RF № 2014145155 "Method of Powder Sorbent Obtaining".
- Patent RF № 2446188 "Method of Workpieces Preparation for Thermoplastic Polymer Composite Nanomaterials for Processing by Pressure in the Solid Phase".

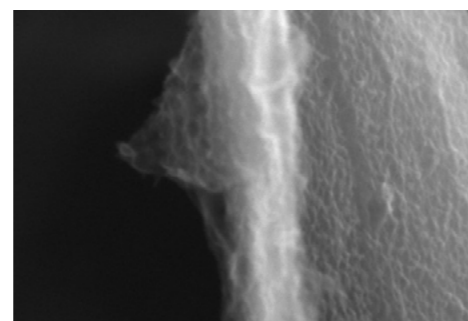

Composite PANI/Graphene

## TECHNOLOGY AND EQUIPMENT FOR PRODUCTION OF FEW AND MULTILAYER GRAPHENE

### Designated purpose, application area.

Few and multilayer graphene nanoplates (GNP) are components of advanced composite materials for various applications with improved mechanical, thermal, electrophysical, electrochemical properties, thermal stability and aging resistance. However, all global developments for obtaining and search for new application areas haven't been brought to industry. TSTU research is focused on development of production technology of high quality industrial GNP with different morphological properties and surface groups.

### Originality, uniqueness.

The proposed technology is characterized by high productivity, low cost of raw materials and high quality of eco-friendly products.

### Specifications.

GNP synthesis method includes oxidation treatment of natural graphite in acid environment with subsequent deintercalation of received intercalated

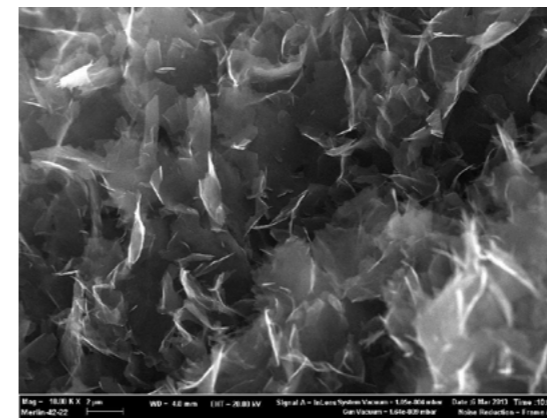

Multilayer GNP (contain oxide groups)

graphite compound. Currently the equipment and optimal technological modes are being developed.

The method allows obtaining GNP, containing 9 ... 15% of surface oxide groups or may not contain them depending on the selected processing option.

Multilayer GNP has thickness of 15 ... 25 graphene

layers, few-layer GNP has 3 ... 5 graphene layers. GNP size at plane is 2 ... 10 mcm. The content of surface oxygen groups improves compatibility of GNP with polar medium.

Diameter of multilayer GNP is 2 ... 10 mcm, thickness is 3...5 of graphene monolayers, multilayer - 15 ... 25 layers, the content of surface oxide groups from absence up to 15 wt. % depending on the applied technology option, design capacity is 0,1 kg graphene per hour, the cost is 50 to 200 dollars per 1 kg, considering technological variant. The picture shows GNP image through electron microscope scanning and transmission.

### Patent documentation:

- Patent Application RF № 2013128041/05(041774) "Method of Graphene Production" is submitted, submission date 18.06.2013.

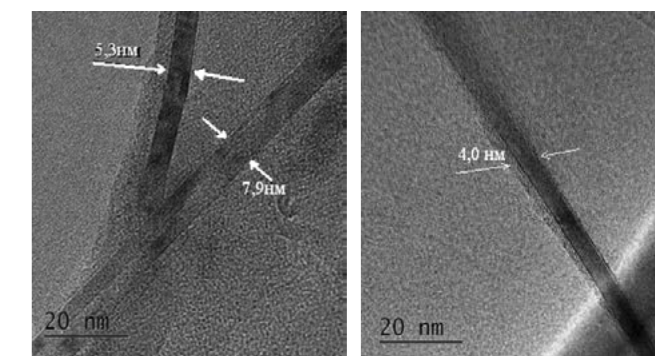

Multilayer GNP

Chair "Technology and Methods of Nanoproducts Manufacturing"

Contact persons: Candidate of Chemical Sciences Dyachkova Tatyana Petrovna

Tel.: +7 (4752) 63-92-93. E-mail: postmaster@kma.tstu.ru

Chair "Technology and Methods of Nanoproducts Manufacturing"

Contact person: Candidate of Chemical Sciences Melezhik Aleksander Vasilyevich

Tel.: +7 (4752) 63-92-93. E-mail: postmaster@kma.tstu.ru



## THERMAL STORAGE HEATER BASED ON NANO-MODIFIED MATERIALS

### Designated purpose, application area.

Thermal storage heater (TSH) is used in power engineering, housing and utilities, automobiles, personal clothing, and technological processes of chemical, petroleum and food industries.

### Originality, uniqueness:

1. Low specific energy consumption in TSH production (high temperature multi-zone furnaces for production of ceramic heating elements are not required).
2. Possibility to configure TSH form due to plasticity that improves the efficiency of heat transfer.
3. Possibility to select the optimum temperature range for technological processes of food and chemical industry (from 18 to 80 °C).
4. Possibility to collect, store the heat of internal and external sources.
5. Possibility of temperature control with resolution of 0,5 °C in 18 ... 80 °C temperature range.
6. Ecological purity (no impurities of heavy metals such as strontium and lead like in ceramic heaters).

### Specifications:

- Temperature range +18 to +80 °C;
- Temperature control with resolution of 0.5 °C in +18 to +80°C temperature range.

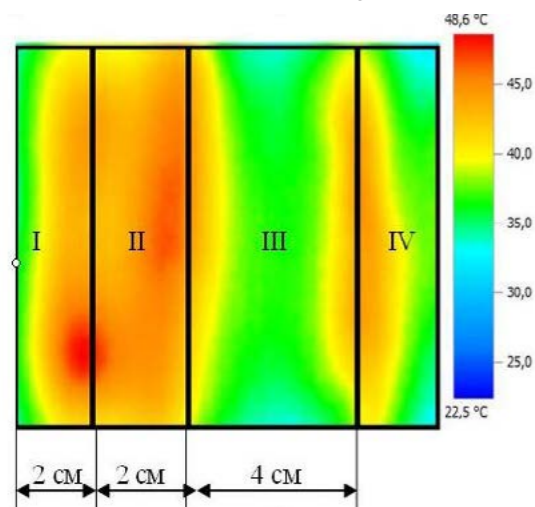

Temperature field at TH surface  
(thermal imaging filming)

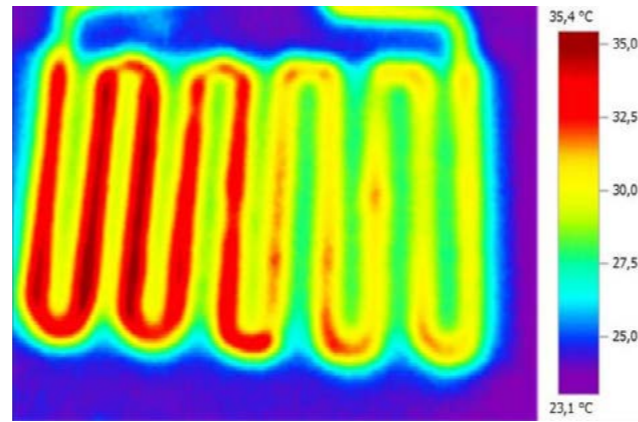

Temperature field of warm floor based on TH (left) and usual electric heater (right) with equal power

- Thermal properties of nanomodified paraffin:
- phase transition temperature range 40 - 80°C;
- heat capacity at phase transition 9.0...11,5 kJ/(kg·°C);
- operating temperature range from 140°C;
- heat capacity after the phase transition 5...6 kJ/(kg·°C).

### Patent documentation:

- Patent RF № 2466333 "Electric Thermal Storage Heater". Authors: Kalinin V. F., Shchegolkov A. V., publication date 10.11.2012.
- Invention summary RF № 2518920 "Electric Thermal Storage Heater". Authors: Shchegolkov A. V., Tkachev A. G., Tkachev M. A., publication date 10.06.2014

LtdLC "Energonanotech"

Contact person: Candidate of Technical sciences Shchegolkov Aleksander Viktorovich

Tel.: +7 920 475-73-37. E-mail: tort12t@mail.ru

## NANOCARBON ADDITIVES FOR CONSTRUCTION MATERIALS MODIFICATION

### Designated purpose, application area.

Complex multifunctional carbon nanoadditives to obtain high-tech concrete and construction materials for various purposes.

### Specifications.

Nanocarbon structuring additives improve physical, mechanical and operational characteristics of construction composites, frost resistance, durability, workability, crack resistance, water resistance of concrete; can reduce cement consumption up to 20% keeping strength characteristics. The samples of nanomodified concrete gain the strength at early time, in average 30 ... 40%, and in a project duration the compressive strength and flexural strength are 25 ... 30% more than in the samples without additives at concentration of CNM 0,0006% by weight of cement.

**Originality, uniqueness.** Nanomodified light concrete results demonstrated that the strength of foam concrete increase 1,5-2 times, water absorption reduces by 45 ... 50% due to more compact structure of composite. The strength characteristics of nanomodified foam glass are 1,5-2 times higher than the control samples.

Forms of CNM-based modifiers:

- dry mixture CNM "Taunit" and surfactants;
- CNM colloidal solution in water;
- concentrate of CNM and plasticizer;
- gel dispersion of CNM;
- tablet form of CNM;
- graphene oxide solution;
- functionalized CNM;
- complex additive based on CNT and zeolites.

### Patent documentation:

- Patent RF № 2494961 "Dispersion of Carbon Nanotubes". Authors: Tkachev A. G., Melezhik A.V., Artemov V. N., Tkachev M. A., Mikhaleva Z.A., publication date 04.03.2011;
- Patent RF № 2482082 "Nanomodifier of Construction Materials and its Production

Method". Authors: Tkachev A. G., Pasko A. A., Artemov V. N., Tkachev M.A., Melezhik A.V., publication date 20.05.2013;

- Conformity Certificate issued by certification system for nanotechnology products "Nanocertifika" № POCRRU. U750.11HЖ02.000035 "Additive to Construction and Concrete Solutions".

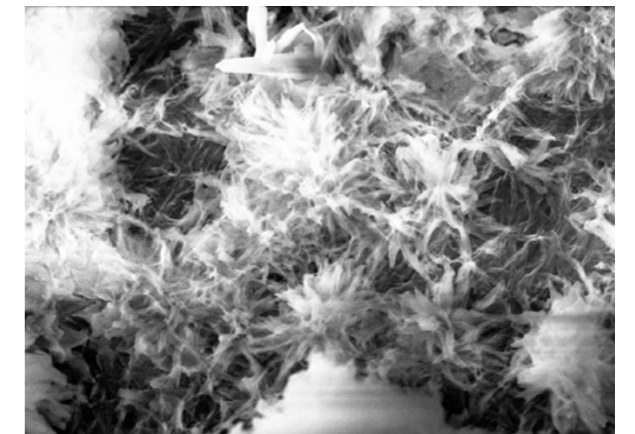
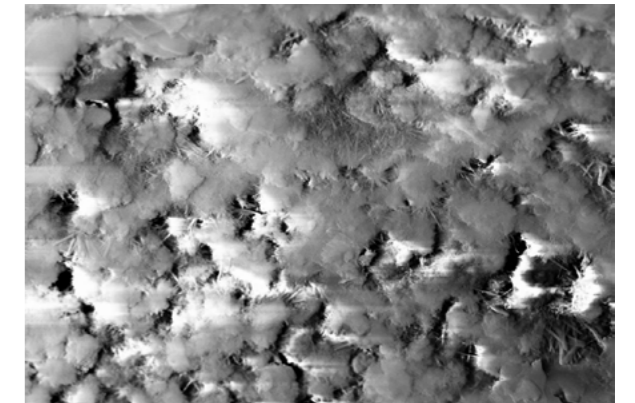

Electron microphotos of unmodified structure (top) and of nanomodified grained concrete

Chair "Technology and Methods of Nanoproducts Manufacturing"

Contact person: Candidate of Technical Sciences Mikhaleva Zoya Alekseevna

Tel.: +7 4752 63-92-93. E-mail: nanotam@yandex.ru



## MULTILAYER SORPTION MATERIALS TO CLEAN WATER MEDIUM FROM RADIONUCLIDES BASED ON MINERAL SORBENTS AND SYNTHESIZED CARBON NANOMATERIALS

### Designated purpose, application area.

Fine purification of water solutions (extraction of ions of heavy metals, organic compounds, etc.), including electrical sorption method, comprising electrochemical and physical effects complex affecting the adsorption processes and water environments conversion, is intended for regeneration of waste water, water treatment complex – obtaining of technical, potable water, quality purification from various liquid medium, used in high-tech industries (microelectronics, pharmaceuticals, robotics, nuclear and hydrogen energy, clean technologies).

### Originality, uniqueness.

New method of industrial sorbents obtaining based on various types of activated carbon (stone, wood, compacted plant material, polymer) and zeolite materials (natural and synthetic), modified with carbon nanotubes is offered. This method provides extension of traditional materials application spheres, including operation with difficult to extract pollutants such as sewage treatment from ions of heavy metals and radionuclides.

### Specifications.

The adsorption capacity increase and selectivity of the new created sorbents is possible due to the unique properties of carbon nanotubes: high adsorption characteristics, possibility to change the surface

chemistry and structural features of nanometer range, which are determined by the method and parameters of synthesis, including the pore space of the carrier. The set of proposed methods allows to create product that can be import substituting and competitive at the world markets of high-performance sorbents.

### Patent documentation:

- *Patent RF № 2501602 “Mixture for Complex Granulated Nanosorbent Obtaining”. Authors: Tkachev A.G., Artemov V.N., Tkachev M.A., Blinov S.V., Burakov A.E., Shubin I.N., publication date 20.12.2013.*
- *Application for Invention RF № 2012109113 “Complex Granulated Nanosorbent”. Authors: Tkachev A.G., Artemov V.N., Tkachev M.A., Blinov S.V., Burakov A.E., Shubin I.N., publication date 29.09.2013.*

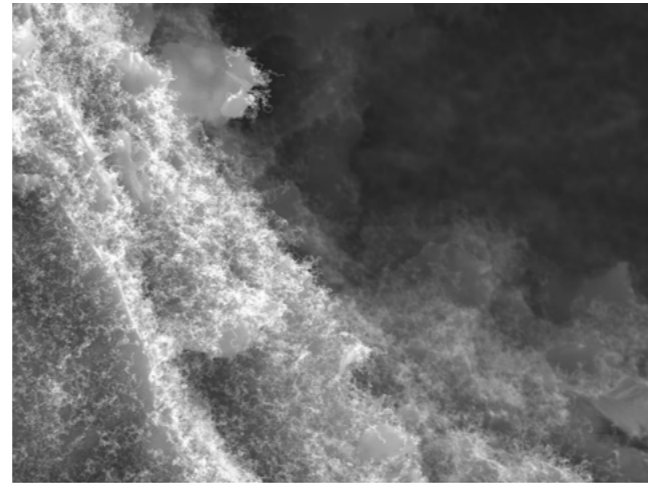
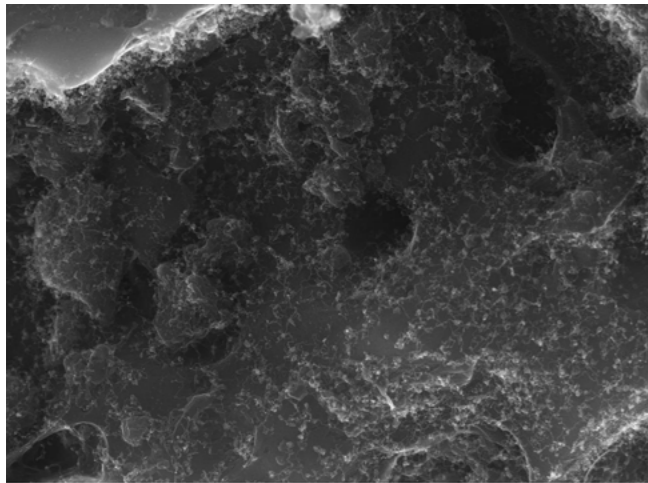

Chair “Technology and Methods of Nanoproducts Manufacturing”, LtdLC “Nanofilter”, ESPU “Neorganika”, Vernadsky Institute of Geochemistry and Analytical Chemistry of RAS  
Contact person: Candidate of Technical Sciences Burakov Aleksander Evgenyevich  
Tel.: +7 920 232-77-35. E-mail: m-alex1983@yandex.ru

## FUNCTIONAL NANOMATERIALS OF HYPERFINE LIQUIDS CLEANING AND GASES AEROSOL FILTRATION

### Designated purpose, application area.

High performance microfiltration of liquids from the micron and submicron particles and superfine cleaning of gas environment from suspended aerosol particles.

### Originality, uniqueness.

The project research objective is efficient technologies development of nanocarbon modification of standard filter materials in order to intensify the filtration process through the creation of porous permeable layer on the surface of filter fibers. Process of such filter structure development presupposes insignificant pressure drop and trapping increase.

The methods of nanocarbon modification of high temperature filter materials (ceramics, pyroceram, metals), activated carbons, sorbents and synthetic polymer membranes are developed. Number of formation parameters of porous permeable membranes of carbon nanomaterials on the modified materials surface are studied and the prototypes with improved characteristics are obtained.

There are three results of intellectual activity.

### Specifications.

The characteristics, obtained by this technology of synthesis of carbon nanomaterials “Taunit” are determined by customers’ demand.

Prototypes with improved quality based on inorganic fibers (siliceous, ceramic, glass-ceramic, etc.) coated with the porous structure of the synthesized carbon nanotubes with specific parameters are obtained.

### Patent documentation:

- *Patent RF № 2411069 “Modifying Method of Inorganic Membrane Porous Structure by Carbon Nanomaterial”. Authors: Tkachev A.G., Burakov A.E., Ivanova I.V., Burakova E.A.*
- *Patent RF № 106253 “Reactor for Carbon Fiber Structures Obtaining by Catalytic Pyrolysis”. Authors: Tkachev A.G., Burakova E.A., Kobtseva Y.A., Ivanova I.V., Burakov A.E.*

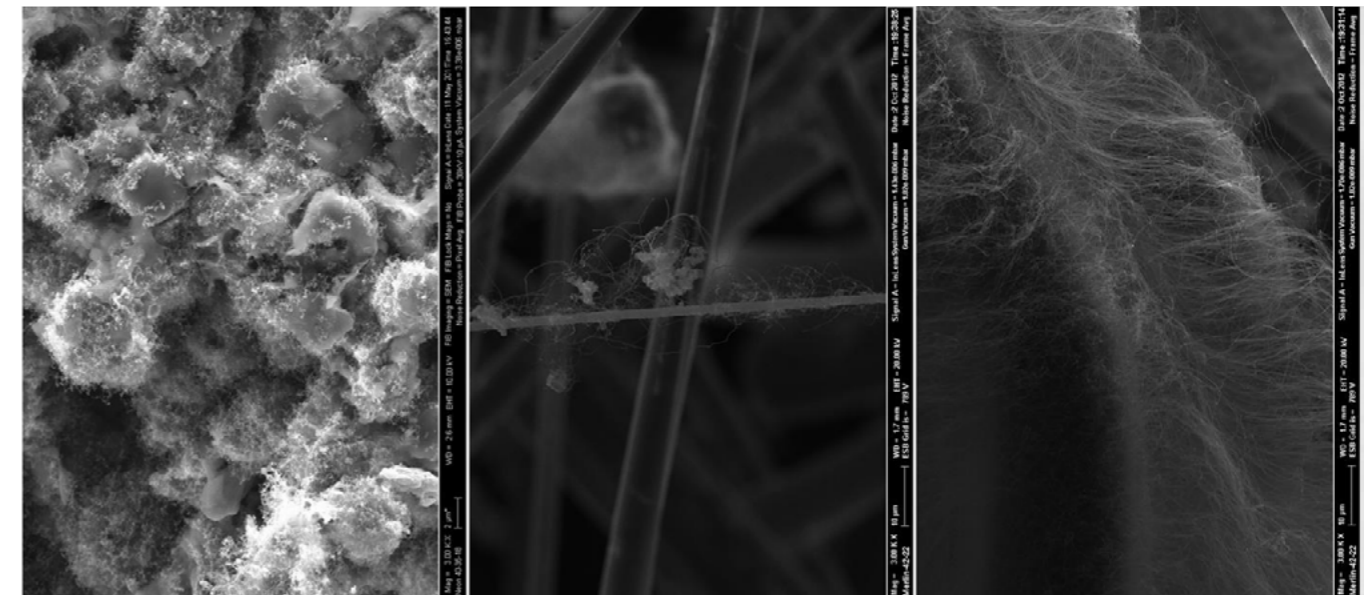

Chair “Technology and Methods of Nanoproducts Manufacturing”, LtdLC “Nanofilter”, NRC “Kurchatov Institute”  
Contact person: Candidate of Technical Sciences Burakov Aleksander Evgenyevich  
Tel.: +7 920 232-77-35. E-mail: m-alex1983@yandex.ru



## MULTIFUNCTIONAL POLYMER AND COMPOSITE MATERIALS NANOMODIFIED WITH CARBON NANOTUBES

### Designated purpose, application area.

Application of nanomodified polymer materials in industries:

- chemical;
- atomic;
- aviation;
- radioelectronics;
- consumer goods;
- power engineering;
- shipbuilding;
- anticorrosion systems;
- transport;
- construction and infrastructure, etc.

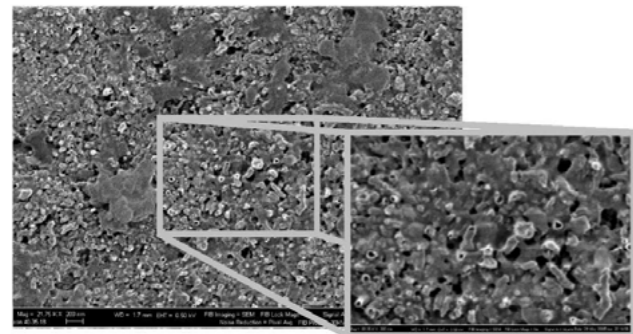

Composite structure  
according to scanning electron microscopy

### Originality, uniqueness.

Developed approaches to obtain nanomodified polymer and composite materials are applied in solid nano-dispersed fraction distribution as high viscosity binder. Materials, obtained by these approaches, can improve their combined physical and mechanical properties to a level unachievable by traditional approaches.

### Specifications.

Nanomodification improves properties of most polymers as thermoplastics and thermosets when the percentage of additive is about 0.01 to 1% (wt.), strength of crack resistance, water resistance increase or properties not typical for polymers such as electric

and thermal conductivity are acquired. The carbon nanomaterial "Taunit" application in epoxy matrix lowered its resistance from 108 to 2.5 ohm/m. The strength of hardened epoxy resin increases up to 20 ... 30%, and the composites elasticity increases in several times. Concentrates containing carbon nanomaterial up to 12% (wt.) maintain storage stability.

### Patent documentation:

- Application for Invention № 2013146447 is submitted.

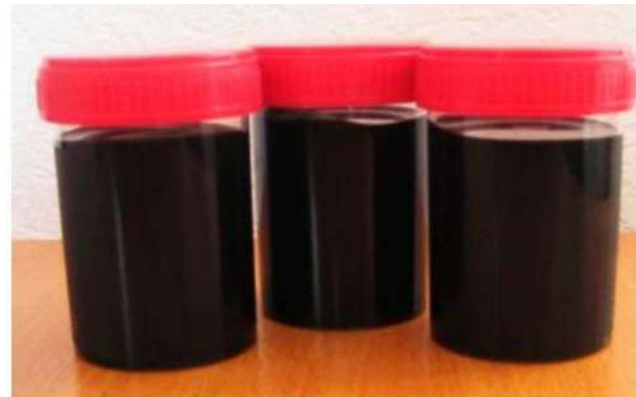

Epoxy-diane resin ЭД-22, modified with carbon nanotubes

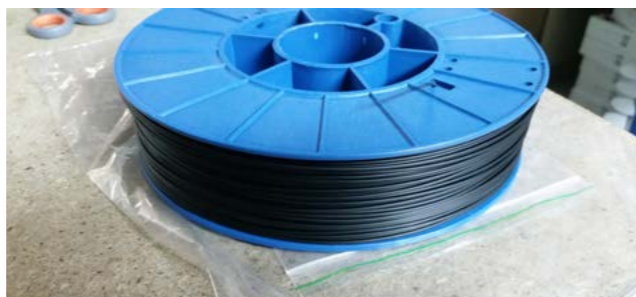

Electrically conductive polymer with resistance 0.3 ohm/m  
based on CNT and ABS

Chair "Technology and Methods of Nanoproducts Manufacturing"

Contact person: Candidate of Technical Sciences Blokhin Aleksander Nikolayevich

Tel.: +7 4752 63-92-93. E-mail: postmaster@kma.tstu.ru

## OBTAINING NANOMODIFIED GALVANIC AND ELECTROCHEMICAL COATINGS WITH IMPROVED QUALITY INDICATORS

### Designated purpose, application area.

The application of functional galvanic coatings with high wear resistance, corrosion resistance, microhardness, heat transfer in mechanical engineering. Application: galvanic departments of mechanical engineering companies.

### Originality, uniqueness.

The developed technologies are more profitable than analogues with nanodiamonds in galvanic electrolytes and have high quality indicators.

### Specifications.

The coatings are obtained from galvanic electrolytes with nanocarbon material "Taunit" addition. Wear resistance and microhardness of nickel, chromium, palladium, silver coatings increase by 20%; corrosion resistance of zinc coatings increases by 10%; heat transfer from oxide electrochemical coatings of aluminum increases by 25%.

### Patent documentation:

- Patent RF № 2411308 МПК C25D 15/00. БИ № 4, 2011. "Nanomodified Electrolyte for Electrochemical Deposition of Nickel Coating".
- Patent RF № 2411309 МПК C25D 15/00. БИ № 4, 2011. "Method for Nanomodified Galvanic Nickel Coating Obtaining".

- Patent RF № 2422562 МПК C25D 15/00. БИ № 18, 2011. "Method for Nanomodified Galvanic Chromium Coating Obtaining".
- Patent RF № 2422563 МПК C25D 15/00. БИ № 18, 2011. "Electrolyte for Electrochemical Deposition of Composite Chromium Coating".
- Patent RF № 2477341 МПК C25D15/00, B82B1/00. БИ № 7, 2013. "Method of Electrolyte Preparing for Obtaining Composite Metal-Based Coatings".
- Patent RF № 2482227 МПК C25D 21/14, G05D 11/00. БИ № 14, 2013. "Method of Nanomodified Electrolyte Adjusting".

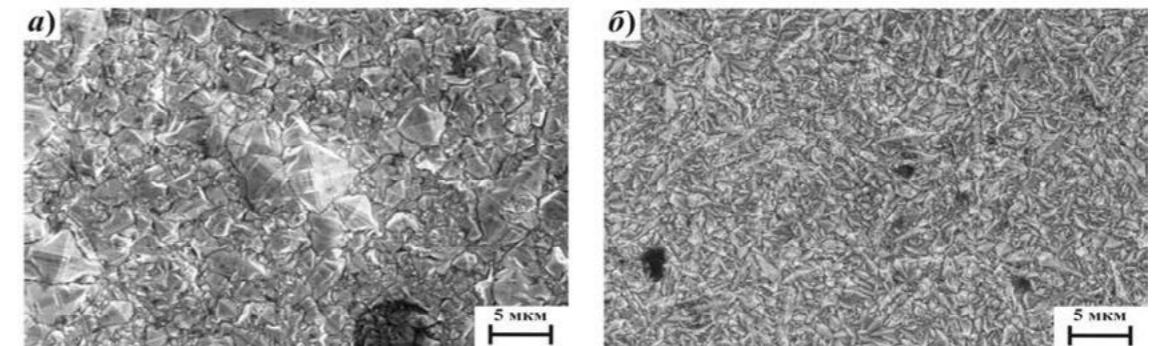

Coatings structure:  
a – non-modified coating; б – modified coating

Chairs "Automated Systems for Decision-Making Support", "Technology and Methods of Nanoproducts Manufacturing", Ltd LC "Nanogalvanics"

Contact person: Doctor of Technical Sciences Litovka Yuri Vladimirovich

Tel.: +7 905 121-61-15. E-mail: polychem@list.ru



## DEVELOPMENT OF STRUCTURE AND PRODUCTION TECHNOLOGY OF COMBUSTION MODIFIERS TO IMPROVE DETONATION RESISTANCE OF MOTOR GASOLINES

### Designated purpose, application area.

Increase of motor gasolines detonation resistance.

### Originality, uniqueness.

Due to electron-hole properties of built from nanotubes graphene structures, a catalytic decomposition of organic peroxides on the surface of carbon nanotubes preventing the spread of detonation wave is observed.

The effectiveness of developed compositions is confirmed by test reports of JSC "VNIIP" (№ 29/14-3-86 dated 14.02.12, № 29/14-3-86 dated 14.02.12, № 29/14-3-86 dated 14.02.12) and also by Conformity Certificate of nanotechnology industry voluntary certification system "NANOCERTIFICA" (№ ROSS RU.I750.HЖ02.000036 dated 07.12.2012 r.)

### Patent documentation:

- Patent RF № 2494139 "Multifunctional Additives to Motor Gasoline and Fuel Composition". Authors: Tkachev A.G., Slepov S.K., Tkachev M.A., Artemov V.N., publication date 27.09.2013.



Pilot device to obtain additives.  
Capacity 450 ...500 l/shift (for 5000 tons of gasoline)

Parameters	Value
Solution density $d_{20}$ , g/sm <sup>3</sup> , not less	0,80
Mass fraction of isopropyl alcohol, weight. %	92,5±2,5
Mass fraction of surfactants, weight. %, not less	6,0
Mass fraction of CNM "Taunit", weight. %, not less	1,5
Octane number of mixture of isooctane and n-heptane in the ratio of 70:30 by volume, adding a modifier 1,0...1,6×10 <sup>-4</sup> wt. % MMA and 1,5 wt. %, not less	8,0
Hazard class	3

Chair "Technology and Methods of Nanoproducts Manufacturing"

Contact person: Candidate of Technical Sciences Memetov Nariman Rustemovich

Tel.: +7 4752 63-92-93. E-mail: nanotam@yandex.ru

## SYNTHESIS OF ULTRAFINE OXIDES IN LOW-TEMPERATURE PLASMA

### Designated purpose, application area.

Ultrafine oxide materials (nanomaterials) are widely used in the production of ferrite and thermistors. Now oxides are used to produce capacitors and supercapacitors, as well as a battery depolarizer. Oxides are applied as pigments for paint materials (enamels, paints) manufacturing, as well as for dyeing plastics, rubbers, synthetic fibers and plastic films, paper, artificial leather, construction materials, etc.

One of the perspective chemical methods of obtaining the ultrafine powders of nitrides, carbides, silicides, borides and oxides is a plasma-chemical method. The main disadvantages of classical methods are broad particle size distribution (single crystals from 10 to 500 nm), and distribution according to the chemical composition, i.e., low selectivity, as well as high content of relatively large (up to 1 ... 5 microns) particles. Due to these rates classical methods of plasma chemical synthesis aren't widely distributed for the production of nanomaterials.

To reduce these disadvantages the revision and adaptation of plasma torch for necessary modes of synthesis of ultrafine oxide materials were conducted (composition of electrodes, plasma forming gas, feed rate of material, plasma forming current were chosen). All these processes reduce the dispersion of oxides granulometric structure. To increase selectivity of the chemical composition in the area of plasma-chemical

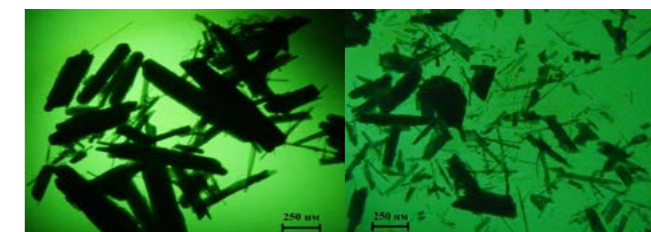

Ultrafine powder of manganese oxide before (left) and after plasma torch treatment

synthesis the external modulated electromagnetic field was applied. Complex modulation parameters of external electromagnetic field (frequency and form of modulation) were experimentally determined, it increases the percentage of output materials with a given oxidation degree.

### Patent documentation:

- Patent RF № 2371381 "Method and Mechanism of Plasmachemical Synthesis of Nanoobjects".
- Patent RF № 2411513 "Method of Identifying and Monitoring the Concentration of Nanoobjects in a Dispersion Medium".

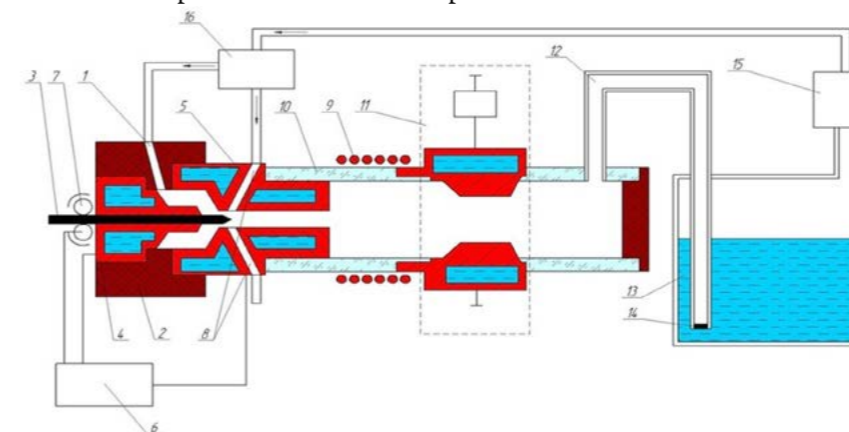

1 – hole in dielectric frame; 2 – dielectric frame; 3 – cathode; 4 – cathode holder; 5 – anode; 6 – device for cathode automatic movement; 7 – rolls; 8 – powder supply port; 9 – inductor; 10 – operating camera; 11 – high-frequency generator; 12 – output tube; 13 – reservoir; 14 – net; 15 – pneumatic pump; 16 – gas-carrier distributor.

Chairs "Materials and Technology", "Criminal Law and Applied Computer Science in Law"

Contact person: Doctor of Technical Sciences Chernyshov Vladimir Nikolayevich

Tel.: +7 4752 63-15-30. E-mail: elters@crimeinfo.jesby. tsu.ru



## OXYGEN-ENRICHED AIR PRODUCTION SYSTEM

**Designated purpose, application area.**

The system allows to produce oxygen-enriched air by pressure swing adsorption method and simultaneously carry out air drying and cleaning from gaseous contaminants. Oxygen-enriched air production system is intended for industrial dehumidifiers, oxygen generators, medical oxygen concentrators.

**Originality, uniqueness.**

Oxygen-enriched air production system in which technology of pressure swing adsorption applied, allows to produce oxygen-enriched air by stepped pressure change in adsorbers without installation of additional heating elements. It provides the possibility of prolonged work (up to 30 000 hours) decreasing electrical energy consumption.



Lab stand of oxygen-enriched air production system:  
1 – control valve; 2 – rotameter; 3 – multichannel flow meter;  
4 – manometer; 5 a, b – absorbers; 6 – moisture-in-gas meter;  
7 – oxygen concentration meter; 8 – switch button;  
9 – time relay.

**Specifications.** Implementation of the technology allows to get oxygen-enriched air stream purified from gaseous impurities, dried until the dew point of  $-40\text{ }^{\circ}\text{C}$ , containing from 30% (at a rate of 10

... 12 l/min output) to 90% oxygen (at a rate of 2 ..3 l/min at the output) with energy consumption 100 ... 150 watts.

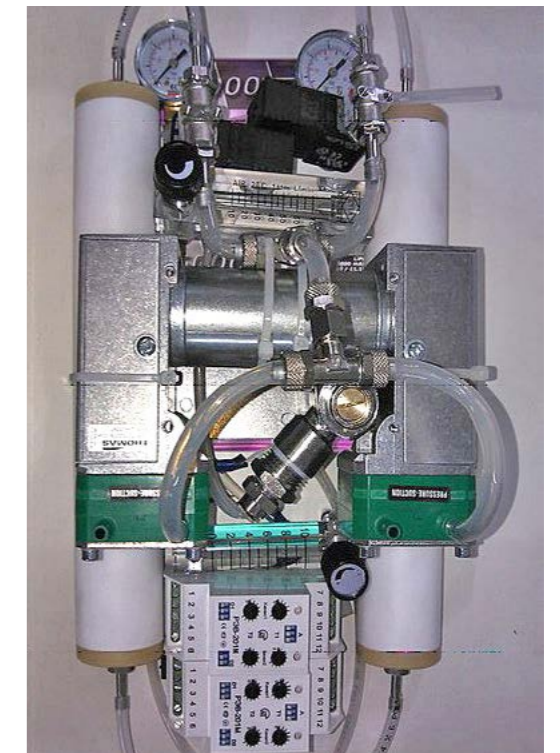

Pilot-scale oxygen-enriched air production system

**Patent documentation:**

- Patent No. 136976 "Adsorption Oxygen Generator". Authors: Akulinin E. I., Dvoret-sky D. S., Temnov M. S.
- Patent No. 96338 "Adsorber". Authors: Akulinin E. I., Dvoret-skiy D. S., Dvoret-skiy S. I., Ermakov A. A., Simanenkov S. I.
- Patent No. 146571 "Adsorber". Authors: Akulinin E. I., Dvoret-skiy D. S., Ermakov A. A., Putin S. B., Simanenkov S. I., Simanenkov E. I.

Chair "Technology and Equipment for Food and Chemical Production"

Contact person: Candidate of Technical Sciences Akulinin Evgeniy Igorevich

Tel: +7 4752 63-94-42. E-mail: akulinin-2006@yandex.ru

# Energy Efficiency and Energy Saving

## CONCRETE-POLYMER COMPOSITES MODIFIED BY INTRODUCTION OF POWDERY AND INDUSTRIAL WASTES

### Designated purpose, application area.

Construction polymer composites are characterized by high performance, but their widespread use is limited by high cost. The use of powdery industrial wastes as a modifier not only allows improving physical-mechanical properties of the material, but also reducing its cost and utilizing large-tonnage waste, reducing human impact on the environment. Developed composites can be successfully used in manufacturing of building constructions and finishing elements for aggressive environmental conditions.

### Originality, uniqueness.

Uniqueness is in enhancing the quality of existing construction materials, reducing their costs and utilizing wastes, which negatively affects the environment.

Compositions of polymer concrete based on thermoreactive pitches (polyester resins and epoxy) containing industrial wastes were developed: phosphogypsum, broken glass, asbestos-frictional wastes and ceramsite sand. Powdery wastes can be added in the amount of 3...6% based on the total weight of the mixture depending on the modifier type.

The compositions possessing the increased durability to different stress-strain states, hardness (increased in 7...35%), heat and UV-ageing resistance, reduced water absorption (reduction up to 50%).

The materials are studied from the kinetic theory points of view of strength and deformation of solids, which allow predicting performance of materials under wide range of influences.

Thermo-physical characteristics are determined



Microstructure of polymer concrete containing 6% broken glass, 64-power magnification

for polymer concrete with ceramsite sand.

The results were implemented into production and used in technical areas floor construction of residential buildings under aggressive influences.



Polymer concrete samples after flexural strength test

Binder	Amount of ceramsite sand, %	Thermal conductivity coefficient $\lambda$ , W/nK	Thermal resistance R, $m^2$ K/W	Heat flow, W/ $m^2$
Epoxy	0	0,399	0,053	651,5
	10	0,376	0,056	620
Polyester resin	0	0,41	0,047	635
	10	0,38	0,051	624

Chair "Structure of Buildings and Constructions"

Contact person: Doctor of Technical Sciences Yartsev Viktor Petrovich

Tel: +7 4752 63-03-80. E-mail: wolk231184@mail.ru

## THERMOPHYSICAL PROPERTIES TEST SYSTEM FOR SALT-PERMEATED WALL MATERIALS

### Designated purpose, application area.

The system is designed to determine the thermophysical properties of salt-permeated wall materials by unsteady pulse method with linear heat source. The invention relates to the field of measurement equipment and can be used to determine the thermophysical properties (thermal diffusivity, thermal conductivity and volumetric heat capacity) of dry and humid wall materials containing hygroscopic salts.

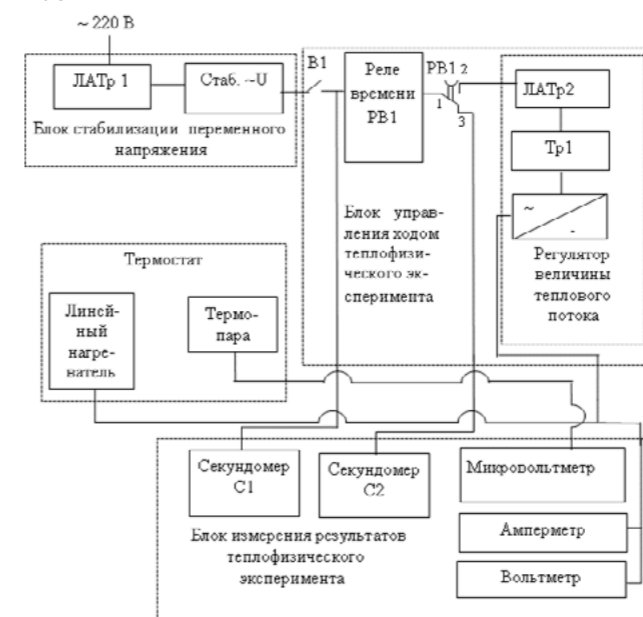

Functional scheme

### Originality, uniqueness.

The system automates process of measuring and determining thermophysical properties of salt-permeated wall materials within salt and moisture phase transition zones due to the short duration of the experiment that excludes drying of wall materials.

Unlike counterparts the system includes: thermophysical control unit, which automates the process of measuring during the experiment; thermophysical results measurement block determining the properties of salt-permeated wall

materials within phase transition zones of moisture and salts with high accuracy by using a block of commercially available digital devices.

Experimental studies, carried out in laboratory, proved salts influence in solid and liquid phases on thermal characteristics of the capillary-porous construction materials.

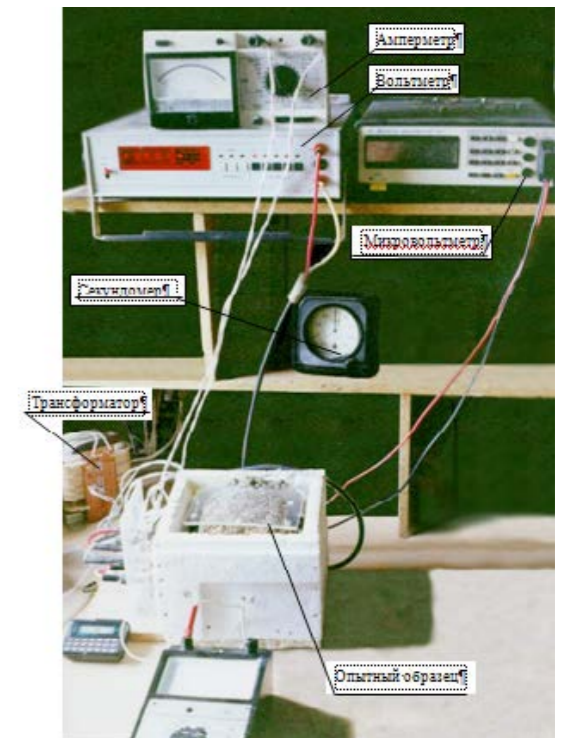

### Patent documentation:

- Patent No. 137738 "The System for Thermophysical Properties Determination of Salt-Permeated Wall Materials by Unsteady Pulse Method with Linear Heat Source". Authors: Elchishev M. A., Elchisheva T. F.

Chair "Architecture and Building Construction"

Contact person: Candidate of Technical Sciences Elchisheva Tatyana Fedorovna

Tel: +7 4752 63-93-73. E-mail: elschevat@mail.ru



## POWER-TECHNOLOGICAL COMPLEX FOR PRODUCTION OF GRANULATED BIOFUEL WITH HIGH THERMO-TECHNICAL PROPERTIES

### Designated purpose, application area.

Power-technological complex is intended to be used in timber and woodworking industries, agriculture, domestic and industrial energy sectors. The complex includes a granulation line, biomass annealing reactor, heat generator to power the reactor, communications pipelines and auxiliary equipment.

### Originality, uniqueness.

The complex provides: increased biofuel volumetric enthalpy on 20 ... 25%; reduction of biofuel transportation costs on 20 ... 25%; reduction of biomass annealing costs on about 50% in comparison with existing technologies.

### Specifications.

Granulation line testing results are as follows: line performance is 2.7 t/h, amount of non-granular biomass content in the final product is 2%, temperature of pellets at the output is 45°C, installed electrical capacity is 170 kW/t.

When testing the reactor it is found that its nominal capacity of granules annealing is 1.1 t/h, annealing temperature is 260°C, annealing duration does not exceed 30 minutes and oxygen content in the

heat treatment zone of the reactor is 3%.

The performance of the heat generator is 600 kW, efficiency-91%, power control range 30 ... 100% of nominal, temperature of heat-transfer medium at the output of the heat generator is 270°C, flue gas temperature is 160°C, temperature of the surface, washed by heat-transfer medium -300°C, stack effect in combustion-chamber of the heat generator is 40 Pa, content of carbon monoxide in flue gases-852 mg/m<sup>3</sup>, sulfur oxides-0, nitrogen oxides-90 mg/m<sup>3</sup> (at 10% concentration of oxygen).

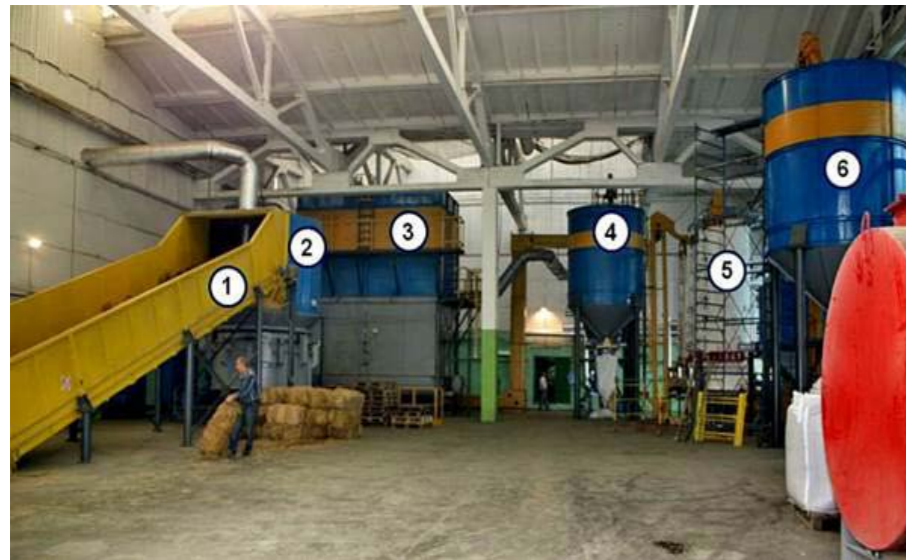

*Power-Technological Complex:*  
1 – loading platform;  
2 – crusher of rough crushing;  
3 – store bunker with filter;  
4 – bunker for the crude (not annealed) granules;  
5 – reactor for granules annealing;  
6 – bunker for annealed granules.

Spin-off company “Pure Energy”

Contact person: Candidate of Technical Sciences Isemin Rafail Lvovich

Tel: +7 4752 63-04-46. E-mail: penergy@list.ru

## PHOTOBIOREACTOR FOR PHOTOSYNTHETIC MICROORGANISMS CULTIVATION

### Designated purpose, application area.

The proposed photobioreactor is used for cultivation of photosynthetic microorganisms biomass to *Chlorella vulgaris* microalgae (ИФР № С-111) in the production of biofuel; raw materials for food and pharmaceutical industry; oxygen released during photosynthesis; regenerations of air in rooms etc.

### Originality, uniqueness.

The proposed photobioreactor has a simple design and the following advantages compared to analog photobioreactors:

- cells are provided with carbon dioxide (for photosynthesis), oxygen (for respiration) by bubbling device (warmed up air/gas mixture flows maintaining temperature steady and appropriate for cultivation), pneumatic mixing allows to provide cells with enough mineral salts for normal activity;
- cells are provided with uniform LED illumination (through bubbling by air/gas

mixture and getting into the area with favorable lighting for all cells) of 25000 lm illumination level (quantum flux 500  $\mu\text{mol}/(\text{m}^2 \cdot \text{s})$ ).

### Specifications.

The application of the photobioreactor is possible in production technology of *Chlorella vulgaris* biomass (IFR No. S-111) with high lipid content (the concentration of cells is 50...60 million in 1 ml of suspension with intracellular lipids up to 35% of cell dry matter).

### Patent documentation:

- RF Utility Model Patent 2014134507 “Photobioreactor” (utility model patent).

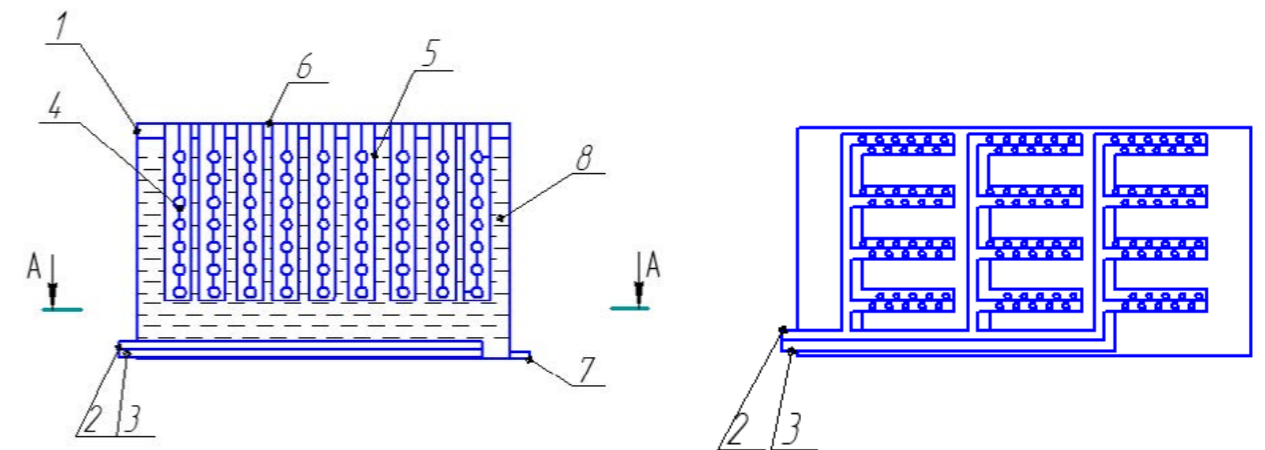

1 – photobioreactor; 2 – system for nutrient medium supply; 3 – system for air/gas mixture supply; 4 – LED tape; 5 – transparent plastic capsule for LED tapes; 6 – photobioreactor cover; 7 – base; 8 – suspension of microalgae

Chair “Technology and Equipment for Food and Chemical Production”

Contact person: Doctor of Technical Sciences Dvoretzky Dmitry Stanislavovich

Tel: +7 4752 63-94-42. E-mail: dvoretzky@tambov.ru

## CONTACTLESS METHODS AND DEVICE FOR LIQUID VISCOSITY CONTROL

### Designated purpose, application area.

The method is intended for control of viscous, aggressive or expensive liquids in various industries, agriculture and medicine.

### Originality, uniqueness.

Application of traditional contact methods of liquid viscosity measurement is associated with certain difficulties: cleaning of measuring containers and sensing elements of measuring devices. Aggressive liquids require structural elements made from special materials. Certain liquids used for industrial and medical purposes are expensive and can be obtained only in small quantities; the fluids do not allow contact with other substances. Contactless methods allow facilitating, accelerating and reducing costs of liquid viscosity measurement process.

Now contactless methods of liquid viscosity control based on different physical effects are developed, but most of them have a number of drawbacks that limit their scope and reduce accuracy. To avoid above-mentioned drawbacks, aerohydrodynamic methods based on speed determination of liquid surface deformation by a gas jet are applied.

### Specifications.

The method and various modifications of the device allow controlling of transparent, not transparent and turbid liquids with glossy and matte surfaces, inhomogeneity of composition, impurities, firm and gaseous inclusions. Measurement range – 0.05...2.00 and 1...200 Pa·s. The main multiplicative error is not more than 3%. Possible options for power supply of measuring devices: electric network, pneumatic line or combined option.

The device can be used in potentially dangerous operating conditions.

### Patent documentation:

- Patent No. 2006136781/28 "Viscosity Control Methods for Moving Liquids and Device for their Implementation". Authors: Mordasov M. M., Savenkov A. P., Kozadaeva M. M.
- Patent No. 2006121846/28 "Physical and Chemical Properties Control Methods for Liquids and Device for their Application». Authors: Mordasov M. M., Mordasov D. M., Savenkov A. P., Kozadaeva M. M.
- Patent No. 99112020/28 "Liquid Viscosity Determination Method". Authors: Mordasov M. M., Trofimov A. V., Galizdra V. I., Trofimov S. A.

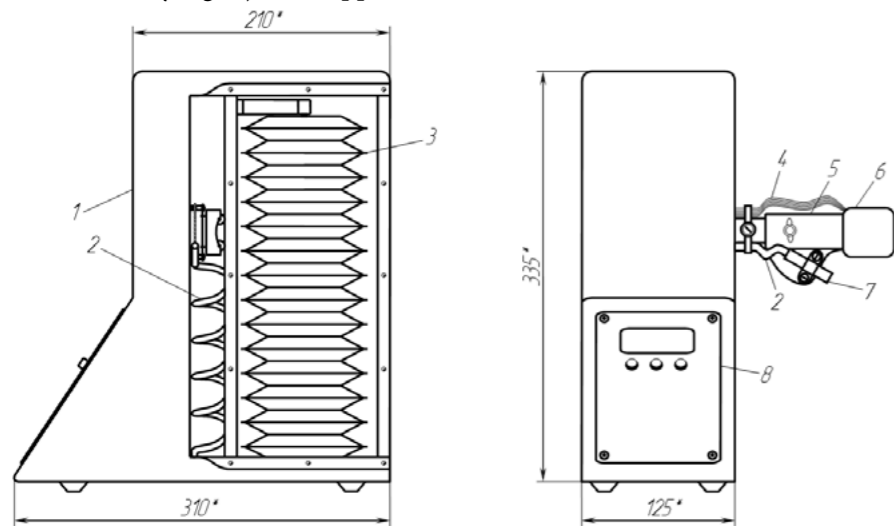

1 – device shell; 2 – hose; 3 – sylphon (bellows); 4 – flat cable; 5 – support bracket; 6 – electronic sensor; 7 – nozzle; 8 – control panel

### Chair "Mechatronics and Technological Measurements"

Contact person: Candidate of Technical Sciences Savenkov Alexander Petrovich

Tel: +7 915 884 30 97. E-mail: savencow@yandex.ru

## TECHNOLOGY AND EQUIPMENT FOR OBTAINING HYDRODYNAMICALLY ENHANCED STRUCTURED WATER

### Designated purpose, application area.

The developed and manufactured device is intended for liquids processing mechanical activation. It is effectively used for obtaining hydrodynamically enhanced structured water. According to the testing results on various objects, the structured water possesses unique properties in comparison with the original one. Technological operating modes are developed to provide the greatest efficiency of final product production.



Device for mechanical activation of liquid media

### Originality, uniqueness.

Advantages of developed technology and hydrodynamic mixer:

- low specific energy consumption;
- simplicity of adjustment and service;
- 30 ... 40% reduction of plasticizing additive products consumption;
- reduction of nano-modifying additive products consumption;
- reduction of cement content in concrete mixture to 1:5 instead of usual 1:3 without strength reduction.

Results of hydrodynamically enhanced structured water application:

- increasing the compressive strength of

concrete in the process of concrete manufacturing: at early stage – to 100%, after 28-days – to 20 ... 50%;

- using concrete mixtures with nano-additives of various nature is additionally increased the strength of concrete to 17 ... 25%;
- for sugar industry - the yield of extracted sugar is increased by 20%
- for ceramic and glass production – durability of products is increased by 30 ... 60%.

The proposed device is universally applicable. It can be applied to carry out and intensify physical and chemical, hydromechanical, heat and mass transfer processes in systems "liquid-liquid", "liquid-gas". The media in the device is exposed to complex influence: cavitation, acoustic, turbulent, mechanical. The special organization of fluid flows and geometrical parameters of the device cause formation of active vortex and resonant operating modes.

The pilot models have productivity to 1 m<sup>3</sup>/h and are powered by standard water supply system.

### Specifications.

- length (with branch pipes) – 300 mm;
- diametrical size (with a branch pipe) – 130 mm;
- weight – 5,5 kg;
- material – stainless steel, brass.

### Patent documentation:

- Two Applications for Invention of hydrodynamic mixer are submitted in 2014.

### Chair "Engineering Mechanics and Machine Parts"

Contact person: Doctor of Technical Sciences Chervyakov Victor Mikhaylovich

Tel: +7 4752 63-04-59. E-mail: tmm-dm@mail.nnn.tstu.ru



## METHODS AND DEVICES FOR QUALITY CONTROL AND DIAGNOSTICS

### Designated purpose, application area.

Methods and devices are intended to determine thermophysical properties of materials, depending on the temperature.

### Specifications.

Devices development and use for:

- nondestructive definition of thermophysical properties of materials;
- nondestructive time/temperature thermal control of structural transformations (phase and relaxation) in polymeric materials;
- nondestructive definition of the melting point of fats in food products (meat, cheeses, confectionery, etc.).



Portable device for nondestructive control of thermal material properties and time/temperature properties of structural transformations in polymeric materials.

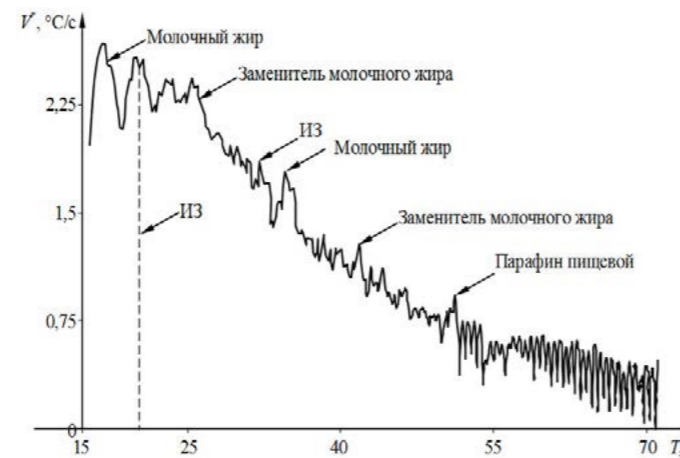
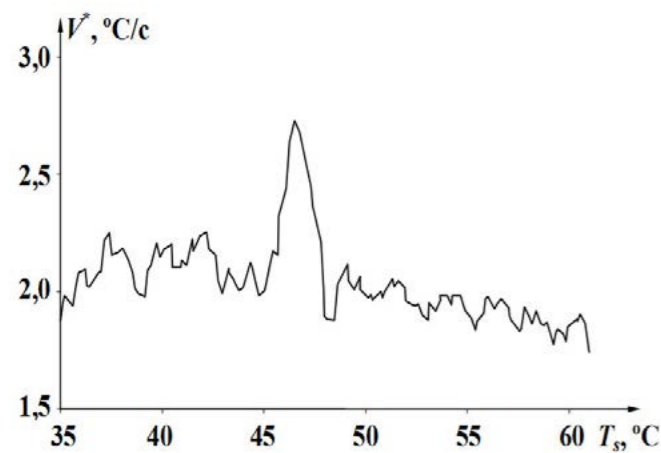

Chair “Enterprise Energy Supply and Heat Engineering”

Contact person: Doctor of Technical Sciences Zhukov Nikolay Pavlovich

Tel: +7 4752 63-04-48. E-mail: zhukov-np@yandex.ru

# Technologies of Food and Processing Industry

## TECHNOLOGY AND EQUIPMENT FOR COMPLEX PROCESSING OF GRAIN MATERIALS

### Designated purpose, application area.

The technology is applied for the complex processing of grain materials by separation, combination, heat and mass transfer methods, including combined methods.

### Originality, uniqueness.

New physical effect is used, i.e. the quasi diffusion separation of particles according to the size, density, roughness, elasticity (this method was discovered and studied by the authors of the project in 1998). It provides possibility of separation processes organization of hard separated materials; production of hard-mixed components mixtures and homogeneous heat and mass exchange processing of materials mixture with different heat and mass transfer properties.

### Specifications:

- separation of mixtures: (grain, seeds, metal slag, ore materials) according to size, density, roughness, elastic particles (separation of non-magnetic metal concentrate out of slag, purification oat from wild oat; size and density seed calibration);
- preparing mixtures of hard compatible components (medical drugs and chemicals, food concentrates, feed). In continuous mixing with micro dosing of components homogeneity of

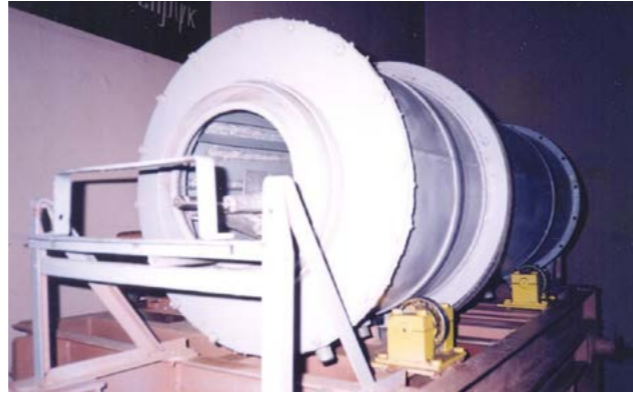

Multipurpose drum machine

mixture increases 10 times comparing with the ideal mixing device;

- homogeneous heat and mass exchange treatment of mixtures of components with different properties (grain mixtures, composites, polydisperse materials) when managing the relation of time processing of the components of material in the range of 0,5 ... 2,0.



Grain cereals, legumes and oilseeds, construction materials, plastics, fertilizers, metal slags

Chair "Technologies and Equipment for Food and Chemical Production"  
Contact person: Doctor of Technical Sciences Dolgunin Viktor Nikolayevich  
Tel.: +7 4752 63-94-42. E-mail: dolgunin-vn@yandex.ru

## DEVELOPMENT OF MILK WHEY BASED FOODSTUFF FOR DIARY MILK PROCESSING PLANT

### Designated purpose, application area.

Milk whey based foodstuff in the form of drinks with brand "VitaMilk" with herbal additives such as fruit syrups, CO<sub>2</sub>-extracts and infusions of herbs, vegetative parts of plants, coffee are intended for various age consumers to quench thirst and restore salt balance in hot climatic seasons, during the active exercise to restore vitality and activate metabolic processes.

### Originality, uniqueness.

Original recipes are offered according to the recommendations on the content of nutrients, nutrition physiology based on recycled natural raw milk unlike the analogues that are made of restored whey with lower biological properties of nutrients because of preservation treatment methods. The technology reduces the effects on the sensitive components of whey and herbal ingredients and simple to be implemented in industry.

### Specifications.

Drinks opaque liquid with pleasant milky taste and aroma of herbal component, colour – green, yellow, cherry, orange. Nutritional value of 100 g product – proteins 0,3...0,6 g, fats 0,06...0,08 g, carbohydrates –



11...16 g. Low-calorie drinks, calorie content 48...65 kcal, contain vitamins: C, B1, B12, B6, minerals – calcium, phosphorus, zinc and molybdenum. The recommended storage time is up to 30 days.

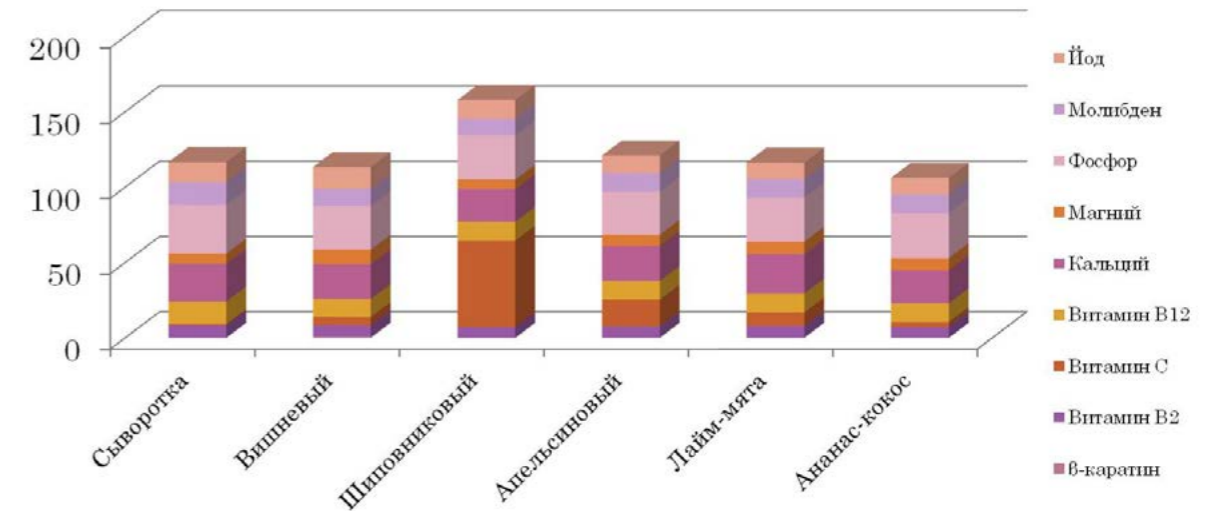

Food and biological value of beverages

Chair "Technologies and Equipment for Food and Chemical Production", JSC "Orbita"  
Contact person: Candidate of Technical Sciences Zyuzina Olga Vladimirovna  
Tel.: +7 4752 63-94-42. E-mail: topt@topt.tstu.ru



## TECHNOLOGY OF FUNCTIONAL PURPOSE CONFECTIONERY AND SOFT DRINKS

### Designated purpose, application area.

The technology involves products manufacturing for healthy diet, creating and marketing a wide range of functional purpose confectionery and drinks in accordance with the physiological needs of different groups of consumers using ecologically clean regional raw plant materials.



### Originality, uniqueness.

New types of confectionery products and soft drinks are different from traditional recipe - the absence of synthetic flavorings and colorings, balanced vitamin and mineral composition, reduced calorie content, improved consumer characteristics, longer expiry date.



### Specifications.

The consumption of the recommended norm of sweets

with carrot powder provides daily carotenoids physiological need for 30...100%.

The consumption of the recommended norm of jelly sweets with pumpkin powder provides daily pectines physiological need for 43...100%.



The consumption of the recommended norm of jelly sweets with added nettle extract provides daily vitamin C physiological need for 25...50%.

### Patent documentation:

- Patent № 2392822 "Method of Production Sweets with Whipped Bodies". Authors: Muratova E. I., Smolikhina P. M., Salikov A. A., Donskikh N. V.
- Patent № 2409215 "Method of Production Jelly Sweets with Phytoadditives". Authors: Muratova E. I., Leonov D. V., Smolikhina P. M.
- Patent № 2497367 "Method of Production Functional Purpose Sweets with Whipped Bodies". Authors: Muratova E. I., Smolikhina P. M., Rodionov Y. V.



## PROCESS OF CULTIVATION OF MICROALGAE CHLORELLA VULGARIS ИФР № С-111 BIOMASS WITH HIGH LIPID CONTENT

### Designated purpose, application area.

Cultivated biomass with high lipid content may be used as new ecological types of raw materials and transformed into environmentally friendly energy sources, for food additives, fertilizers, phospholipids, nutrients for microorganisms cultivation.

### Originality, uniqueness.

The advantages of new Tamiya optimum for the cultivation of the nutrient medium over standard Tamiya medium:

- saving of mineral salts;
- higher growth of cells.

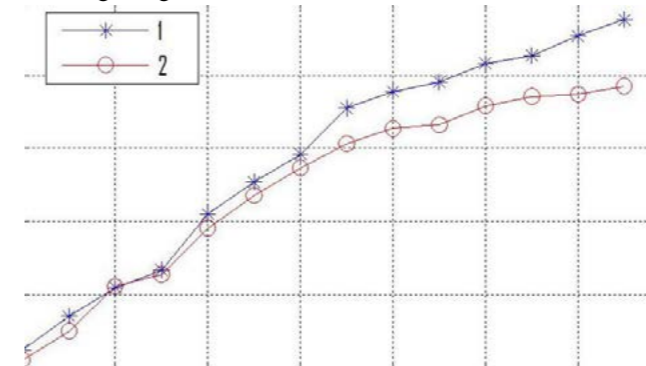

Dynamics of cells growth of strain at Tamiya optimum (1) and Tamiya (2)

### Specifications.

The proposed method of cultivation of biomass *Chlorella vulgaris* ИФР № С-111 with high lipid content includes:

- cultivation of microalgae *Chlorella vulgaris* in nutrient medium Tamiya optimum till the stationary growth phase (50...55 million cells at 1 milliliter of suspension);
- cultivation of received biomass at stress conditions (shortage of nitrogen-containing substances) to stimulate the accumulation of intracellular neutral lipids (triglycerides) for 4 - 7 days.

### Patent documentation:

- Patent RF 2014134567 "Method of Biomass

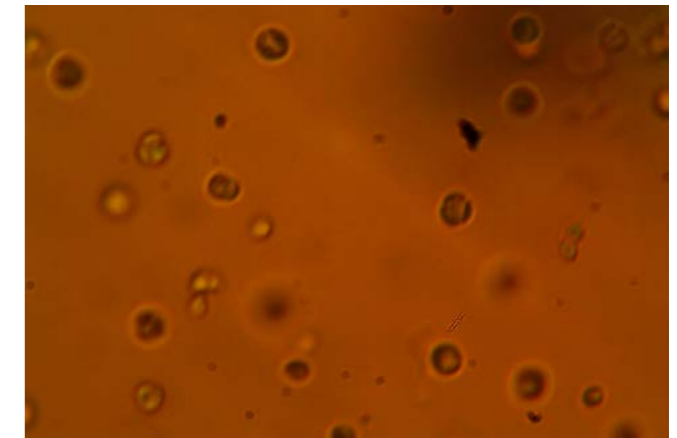

Strain *Chlorella vulgaris* ИФР № С-111

### Cultivation with High Lipid Content

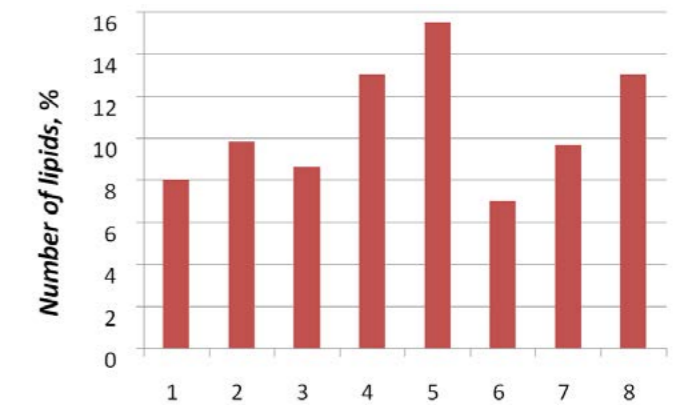

Number of lipids, %:

- 1 – untreated, 2 – treatment with antibiotic solution, 3 – treatment with enzyme solution, 4 – treatment of microwave radiation, 5 – treatment in ABC, 6 – "osmotic shock" by sodium chloride, 7 - "osmotic shock" by sucrose solution, 8 - flocculant treatment.

## IMPROVEMENT OF ROADWAY COVERING QUALITY USING RECYCLED POLYMER MATERIALS WITH ROAD BINDER MODIFICATION

### Designated purpose, application area.

The problems of roadway covering poor quality are caused by imperfect properties of synthetic asphalt used as binding bituminous. Advanced technology presupposes modification of bitumen by thermoplastic elastomer obtaining bituminous plastic binders (BPB), the price of such binders is higher than the price of raw material.

### Originality, uniqueness.

Complex modifiers improve quality of BND bitumen, in such modifiers expensive thermoplastic elastomers (TPE) are replaced by thermoplastic wastes - polymer and polyethylene packages. In such cases the price of BPB is 30...40% lower than market bindings made of TPE. The developed formula of complex modifier consisting of TPE, polyethylene and surface- active adhesive additive decreases 25% of energy costs for production of BPB reducing the processing time. At the same time predetermined dispersion of polyethylene in bitumen and BPB maturation are achieved.

### Specifications.

The obtained modified binder made of thermoplastic wastes by its penetration index is quite similar to BND 60/90 bitumen which is widely used in road construction, its main indexes (ductility,

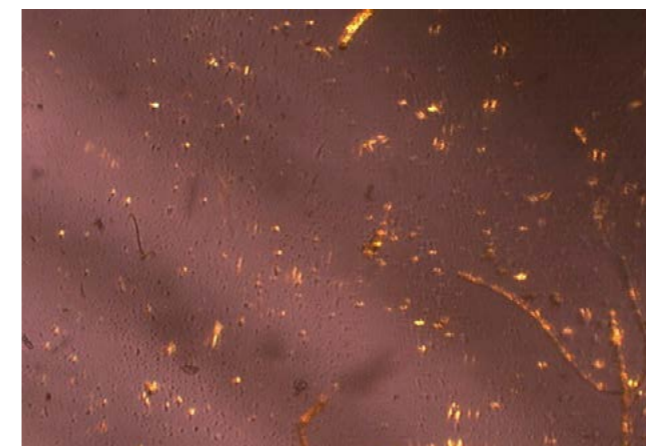

Penetration, ductility, softening temperature, elasticity

softening temperature) are of high quality. Besides, BPB made of thermoplastic wastes has such a characteristic as elasticity while the original bitumen hasn't such property. The obtained BPB meets GOST 52056-2003 requirements for polymer bitumen binders but it has lower cost price.

Price increase of 1 km pavement with the use of BPB is 0,07%. Life time increase of roadway covering is 2-3 times.

### Patent documentation:

- The Patent for PBV formula was submitted in 2015

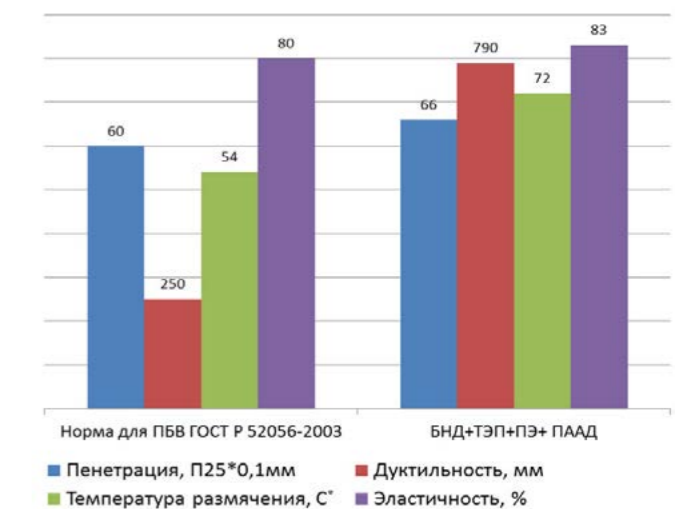

Comparison of BPB indexes with standards GOST P 52056-2003

# Environmental Science and Rational Nature Management

Chair "Polymer Processing and Packaging Production"

Contact person: Doctor of Technical Sciences Belyaev Pavel Serafimovich

Tel.: +7 4752 63-51-74. E-mail: polymers@asp.tstu.ru



## METHOD OF PREDETERMINED QUALITY WATER TREATMENT

### Designated purpose, application area.

Modern industry needs treated water containing certain values of substances concentration. Such water should have all necessary chemical properties due to its content of such microelements as calcium, magnesium, biologically active supplements and other substances.

### Originality, uniqueness.

Commonly used methods not always allow to fulfill such task. So, a special method of predetermined quality water treatment was developed. The main difference of this method is that its implementation doesn't require application of chemical reagents and storage area, also there is no need to use expensive externally supplied heat-transfer agents.

The main technical result achieved using this method is predetermined quality water treatment, water with the composition of mineral and organic substances and its concentration defined by technical regulations of certain industry. These concentrations are usually lower than possible concentrations after the installation of reverse osmosis. Additional technical result is obtaining dry mineral mixtures used as raw material for dispensing microelements into water in blending machine or can be sent to the consumer.

This technology is presented in draft.

### Patent documentation:

- Application for Patent № 2013118974.

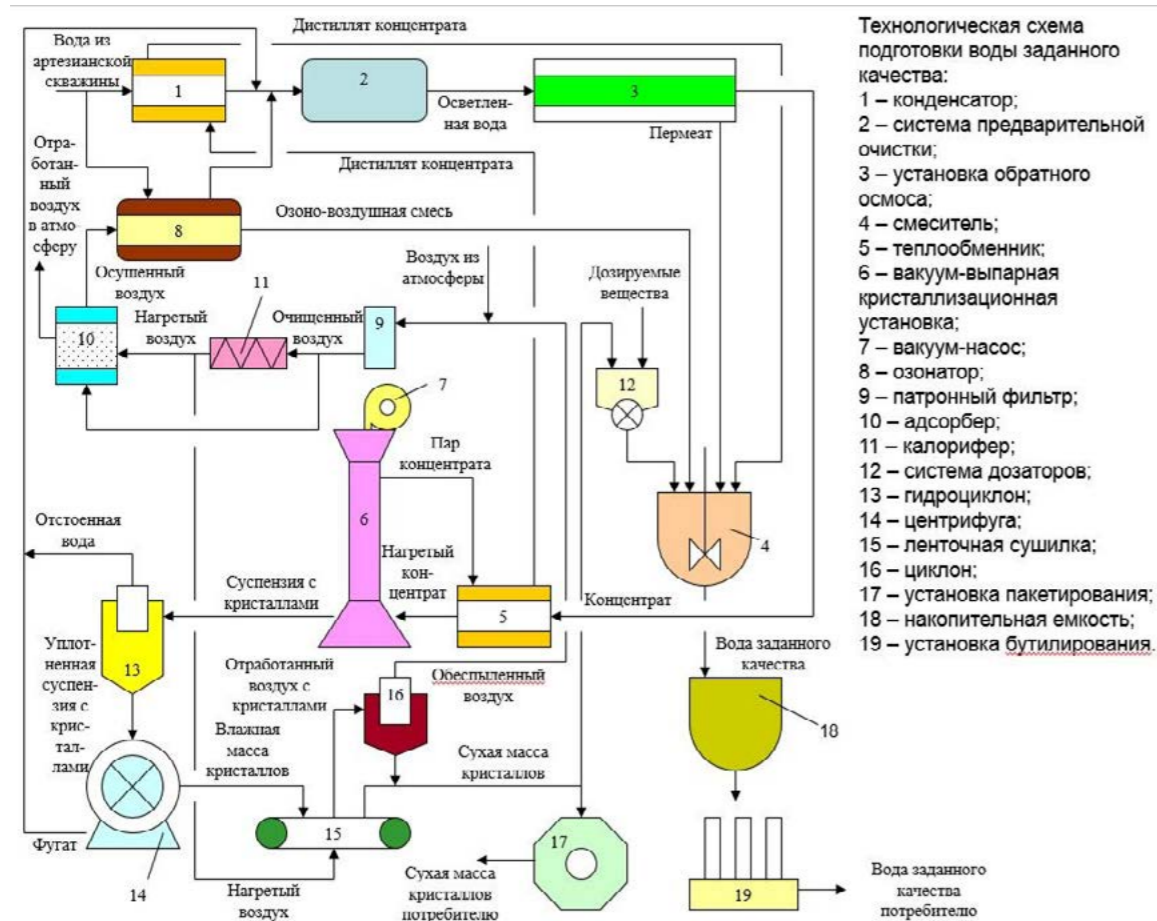

Chair "Nature Management and Environment Protection"  
 Contact person: Candidate of Pedagogical Sciences Kozachek Artemy Vladimirovich  
 Tel: +7 4752 63-03-65. E-mail: eco@nnn.tstu.ru

## TREATMENT OF ALTAX ELECTROCHEMICAL SYNTHESIS WASH WATER BY ELECTRICAL BAROMEMBRANE METHODS

### Designated purpose, application area.

Wash water obtained by washing the base products (reagents) for example altax (2,2'-dibenzothiazol disulphide) used for production of rubber is of high toxicity and before its discharged into water bodies it should be deeply cleaned.

**Originality, uniqueness.** In comparison with the traditional industrial methods of solute treatment membrane methods are not widely used in industry. It's connected with the lack of technology for solute treatment using reverse-osmosis membrane separation while treating certain water supply and necessity to develop devices for permeate abstraction. Prospective design electric drill roll type membrane device allows separate processes solutions with the influence of several driving forces, which affect the quality of separation and the possibility of cooling the permeate.

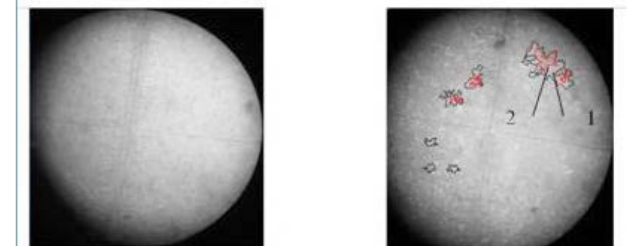

Treated samples of ESPA membranes (microinterferometric pictures):  
 left – cathode; right – anode

### Specifications.

Used in industrial and laboratory practice basic flowsheet processes of baromembrane separation of liquid mixtures with their advantages and disadvantages have been extensively described in the literature but the application of membrane technology for treatment of altax production wash water (2,2'-dibenzothiazol disulphide) was not carried out. In this case we present the scheme of electric baromembrane separation of certain solutions and membrane samples after separation. Multi-stage electric baromembrane devices are used for industrial implementation in the field of membrane processes of technological solutions and flows. Application of such device will increase the area of solutions and process water separation per device unit volume as well as simplify the installation and dismantling of its individual parts after the solutions cleaning process.

### Patent documentation:

- Patent № 2553859 "Electrical Baromembrane Roll Type Device". Authors: Kovalev S. V., Lazarev S. I.

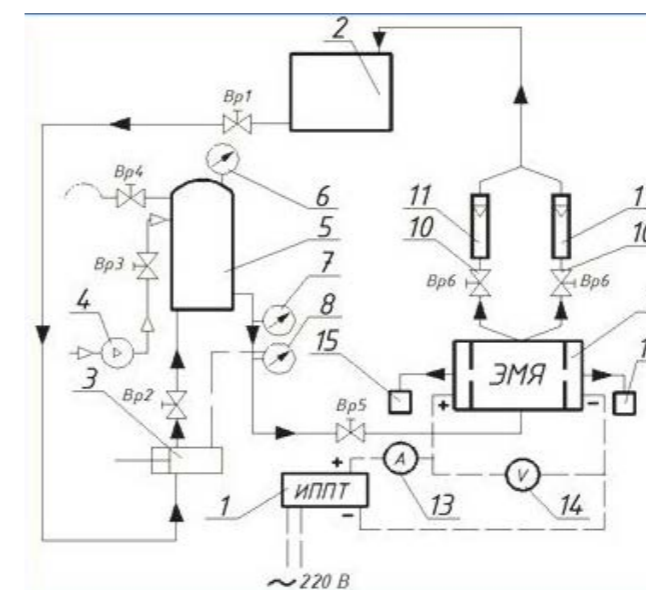

Electrical baromembrane device scheme

Education and research center "Wasteless and Low-Waste Technologies"  
 Contact person: Candidate of Technical Sciences Kovalev Sergey Vladimirovich  
 Tel: +7 4752 63-03-70. E-mail: geometry@mail.nnn.tstu.ru



## MEMBRANE TECHNOLOGY FOR SOLUTIONS SEPARATION OF GALVANIC PRODUCTION PROCESS WATER

### Designated purpose, application area.

Rational use and protection of water resources is a problem of great importance. Galvanic production is one of the most dangerous sources of surface and underground water pollution because of large volume of wastewater which contains contaminants of heavy metals, inorganic acids and alkali, surfactants and other toxic compounds. Contact with untreated or inadequately treated sewage and other waste containing non-ferrous metals in water bodies has caused great damage to the national economy and the environment. One of the solutions of this problem is the sewage treatment that achieves the least negative impact on the environment.

Today membrane systems are among the most effective methods of wastewater treatment. They are the most productive and constitute a set of special semipermeable membranes separating the filtrate from the cleaning solution. The solvent passes through the diaphragm and the solutes are retained by membrane filter. Compared with traditional methods, membrane



Reverse osmosis device

technologies require more compact equipment, low power consumption, drinking and industrial water obtaining, minimal use of chemicals and the ability to automate processing and monitoring of water quality.

### Specifications.

Designed electrical baromembrane device cleans and concentrates industrial solutions, differentially allocates ions of multicomponent systems and obtains highly purified substances.

### Patent documentation:

- Patent № 2326721 "Electrical Baromembrane Roll Type Device". Authors: Lazarev S. I., Abonosimov O. A., Ryabinskiy M. A.

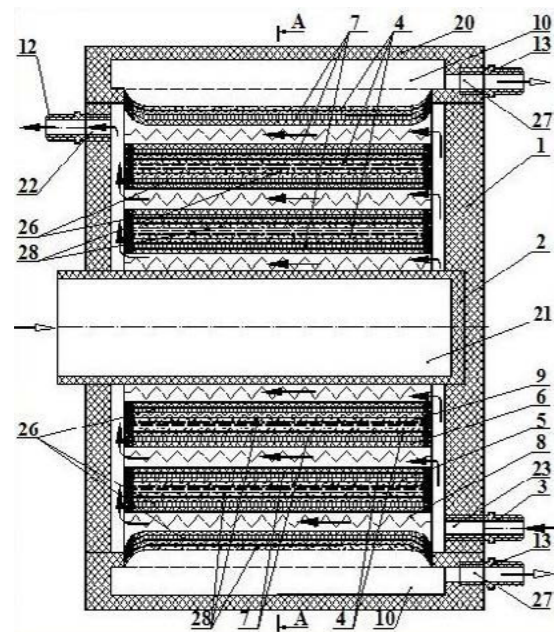

Membrane roll type device

Education and research center "Wasteless and Low-Waste Technologies"  
 Contact person: Candidate of Technical Sciences Abonosimov Oleg Arkadyevich  
 Tel: +7 4752 63-03-70. E-mail: geometry@mail.nnn.tstu.ru

## DEVELOPMENT OF ENERGY EFFICIENT TECHNOLOGY AND EQUIPMENT FOR POLYMER PACKAGES WASTE RECYCLING

### Designated purpose, application area.

Production of recycled raw materials for enterprises which process polymers into goods from waste thermoplastic materials. Recycling waste reduces environmental pollution, improves the regions environmental security, and is an additional source of raw materials, can significantly reduce the cost of products made of polymers and composites.



Roller-screw assembly

### Originality, uniqueness.

The technology provides combination of rolling and extrusion processes in a single unit, eliminating the operation of re-melting polymers and ensure the reduction of energy consumption in the production of recycled granulate from waste. Besides, the technology eliminates the most energy-intensive stage of crushing and drying in the processing of membranous and thin sheets of polymer materials used for packaging. Designed for realization equipment - a roller-screw unit enables continuous process of disposing of thermoplastic polymeric materials waste.

Chair "Polymer Processing and Packaging Production"  
 Contact person: Candidate of Technical Sciences Klinkov Aleksey Stepanovich  
 Tel.: +7 4752 63-51-74. E-mail: polymers@asp.tstu.ru

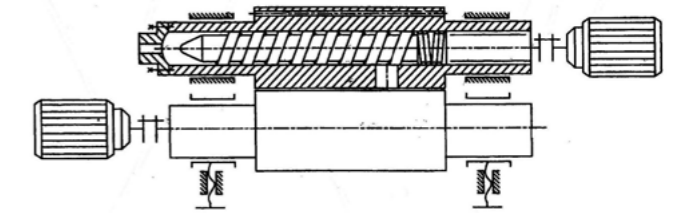

Scheme of roller-screw assembly

### Specifications.

Recycling temperature is about 130...2000 °C, it depends upon the recycling material. Specific power expended to produce 1 kg of product is 0.6 ... 0.8 kW • h / kg, compared with counterparts below 20 ... 25%.



Recycled granulated material produced by roller-screw assembly

### Patent documentation:

- Patent RF № 2417881 "Roller-Screw Assembly". Authors: Klinkov A. S., Makeev P. V., Sokolov M. V., Polushkin D. L., Odnolko V. G.
- Patent RF № 67017 "Auger Device for Rolling Machines". Authors: Polushkin D. L., Klinkov A. S., Sokolov M. V., Belyaev P. S., Odnolko V. G.



## EVALUATION OF NOISE DISTRIBUTION THROUGH THE AIR CHANNELS IN HEATING, VENTILATION AND CONDITIONING SYSTEMS WHILE DESIGNING NOISE REDUCING DEVICES

### Designated purpose, application area.

Methods of calculation and the computer program for the implementation are designed to assess the distribution of acoustic energy through the air channels of heating, ventilation and air-conditioning systems. Data obtained as a result of calculations gives a reasonable choice of the means for reduction of noise in residential and public buildings.

Methods of calculation and the computer program were used in Research Institute for Building Physics RAASN while evaluating noise at power stations in Moscow and the Moscow region, as well as in the evaluation of noise mode in rooms with ventilation systems in the Tambov Regional Library named after A.S. Pushkin.

### Originality, uniqueness.

For the first time calculation method makes it possible to take into account the characteristics of the channel and determine accurately the distribution of the reflected sound energy, depending on the shape, channel cross section, the ratio of its size and nature of barriers absorption.

Solomatin E.O. is one of the creators of calculation method and computer program, got the RF Government award 2014 in the field of science and technology as a young researcher.

### Specifications.

The method is based on the original mathematical model proposed for the description of noise distribution in closed objects. Mathematical model is based on the approach which presupposes simultaneous use of numerical method energy balance and ray tracing method for calculation. Such approach implements mixed specular-diffused reflection of sound from the enclosing surface of air channels.

### Patent documentation:

- *Certificate of Software Registration № 2012613166 "Calculation of Noise Field in Energy Production Areas with Oversized Equipment".*  
Authors: Antonov A. I., Solomatin E. O.

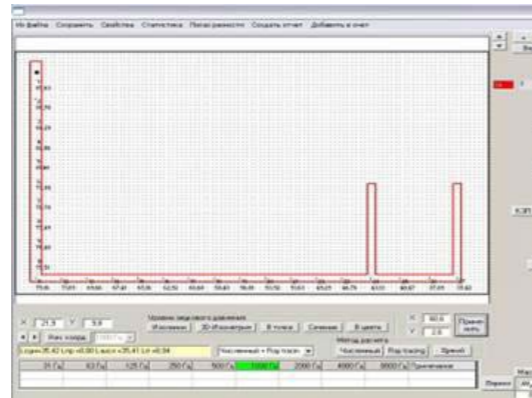
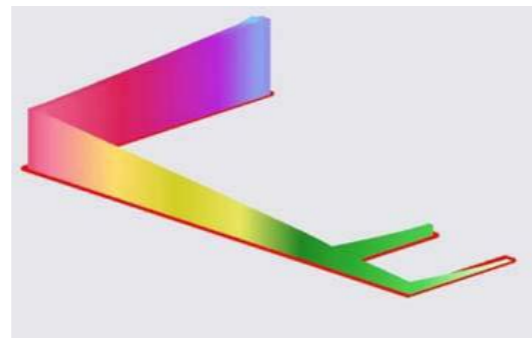

## Information Technologies

Chair "Town Planning and Roads"

Contact person: Doctor of Technical Sciences Ledenev Vladimir Ivanovich

Tel: +7 4752 63-03-72. E-mail: [gsiad@mail.tambov.ru](mailto:gsiad@mail.tambov.ru)

## OPTICAL SYSTEM FOR IMAGING OF STRUCTURAL AND FUNCTIONAL PROPERTIES OF BIOLOGICAL TISSUE SURFACE

### Designated purpose, application area.

The developed system can be used in ophthalmology, dermatology, dentistry, cardiology and gastroenterology. The priority area of application is ophthalmology where optical coherent tomography (OCT) is already used to obtain structural images of the cornea, vitreous body and retina. The system allows both structural and functional (Doppler) imaging. It provides the opportunity for real-time define velocity mapping of normal and pathologic anatomy of biological objects.

### Originality, uniqueness.

Analysis of advanced developments in the field of OCT shows that the main disadvantages of the method of non-invasive diagnostics are small depth of coherent probing of biological tissue (1.2.....1.3 mm) and poor quality of structural and Doppler images.

Improvements in both hardware and software technologies of OCT-systems were offered to address revealed shortcomings, as follows: improved fast scanning optical delay line, an algorithm for constructing a structural image of bio-object, a method of color Doppler mapping of biological fluid flows with opposite directions, a method for rational control over these processes.

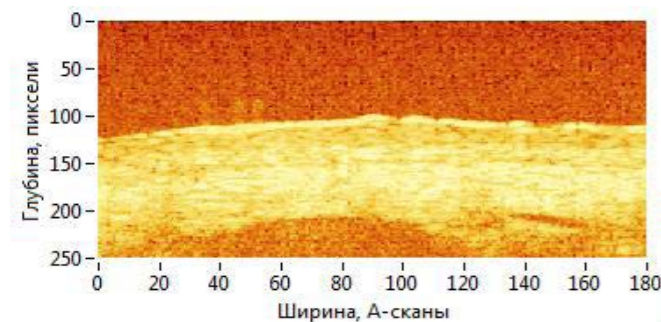

Structural OCT image of human subcutaneous blood vessel: standard result (left), new result (right)

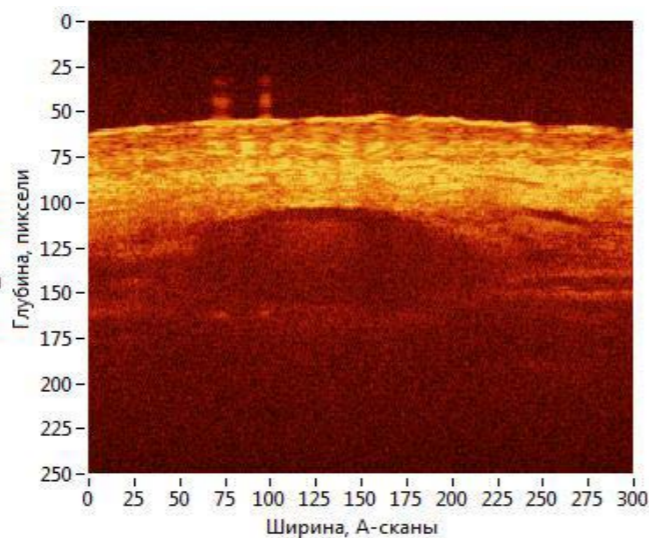

**Specifications.** The system is characterized by 20 ... 30% increased depth of coherent sensing, in comparison with classical OCT systems, absence of  $2\pi$ -ambiguity on Doppler cartograms and increased by 10 dB signal / noise ratio, that allowed to visualize - for the first time - human subcutaneous blood vessels in vivo by OCT and get real-time Doppler equi-velocity maps in norm and pathology.

- structural performance: 1 ... 100 images per second;
- Doppler speed: 1 ... 10 images per second;
- data compression settings: 2 - 3 times;
- spatial resolution: 1 ... 20  $\mu\text{m}$ ;
- definition of speed: 0.3 ... 5000.0  $\mu\text{m} / \text{s}$ ;
- speed accuracy: 2 ... 7%.
- power consumption: less than 700 watts.

### Patent documentation:

- Patent RF No. 2013107910 "Method for Quality Improvement of Bio-Object Structural Image in Optical Coherence Tomography." Authors: Frolov S. V., Proskurin S. G., Potlov A. Yu.

### Chair "Biomedical Engineering"

Contact person: Doctor of Technical Sciences Frolov Sergey Vladimirovich  
Tel: +7 4752 63-56-20. E-mail: sergej.frolov@gmail.com

## COMPUTER AIDED MEASUREMENT SYSTEM FOR PROPERTIES RESEARCH AND CALCULATION OF OPTIMAL CURING MODES OF POLYMER MATERIALS

### Designated purpose, application area.

Computer aided measurement system (CAMS) is designed to study mathematical model parameters of polymer composites curing process based on high-temperature cure binder and to calculate optimal curing modes of products manufactured by hot pressing and vacuum forming technology, curing of wound products in autoclaves.

The system is applied to optimize technological process of curing for thick-wall articles produced from newly developed polymer composites as well as to optimize existing curing technological processes based on mathematical modeling with application of examined parameters of the model.

The system was used to study and calculate optimal modes for curing of the following products: fiberglass, organic plastic, carbon fiber, asbestos-reinforced plastic for the following aircrafts types: An-124 «Ruslan», AN-225 «Mriya», IL-96, Su-47 «Berkut», Airbus A- 380, etc.

### Originality, uniqueness.

In contrast to mass-produced differential scanning calorimeters, CAMS enables to study mathematical model parameters of polymer composites solidification process in conditions similar to technological process, including testing of technological pressure implementation and testing of filled composites with appropriate assembling of pre-preg layers, etc.

CAMS software enables to calculate optimal time-temperature modes for curing of flat products with 2.80 mm thickness. The following parameters are calculated according to the criteria of a minimum duration, energy consumption and residual stresses: number of heating stages, heating rate at each stage, temperature and duration of isothermal exposures.

The main tasks to be solved in selecting the optimal mode of curing polymeric composites, which guarantee high quality along with low products cost are:



Computer aided measurement system - general view

- reduction of temperature and conversion non-homogeneity in polymeric composite materials;
- complete curing of binder;
- elimination of distortion or warp of finished product;
- reduction of curing time;
- reduction of energy consumption.

### Specifications.

CAMS enables to research parameters of curing process mathematical model:

thermal and kinematic curing characteristics; binder parameters of mass transfer; dielectric characteristics. The sample is prepared as a plate of pre-preg layers assembled. The dimension of the plate is 100x100 mm and the thickness is 5 to 30 mm.

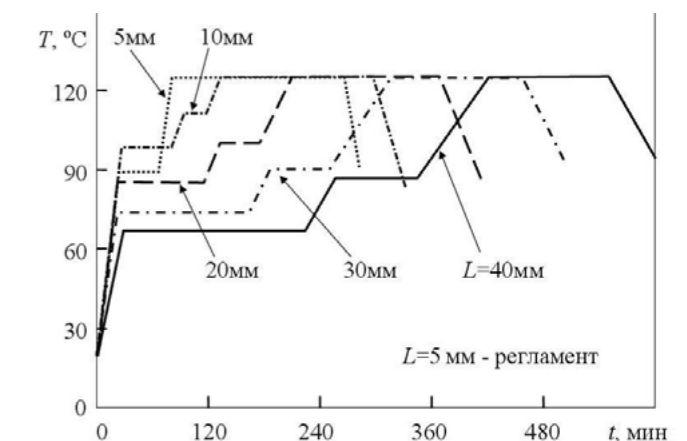

Optimal curing modes for fiberglass panels of different thicknesses

### Chair "Physics"

Contact person: Doctor of Technical Sciences Dmitriev Oleg Sergeevich  
Tel: +7 4752 63-03-69. E-mail: phys@nnn.tstu.ru



## AUTOMATED DEVICE “ARTIFICIAL LUNGS” FOR HUMAN RESPIRATORY PROTECTION EQUIPMENT TESTING

### Designated purpose, application area.

One of the main goals of State policy in the field of individual respiratory protection is to guarantee an appropriate level of human safety from chemical hazards and industrial disasters.

As a consequence, new personal respiratory protection equipment (PRPE) as one of the elements of life support system as well as its components are being developed and require testing at both design and production stages.

The primary device to test respiratory protection equipment and its separate components is “Artificial Lungs” device (AL).

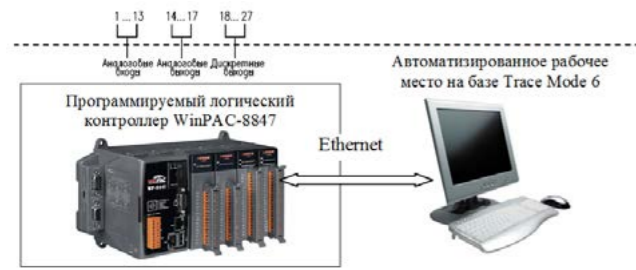

Device automated control system

The automated device (AL) can be used to:

- increase knowledge by developing new competitive products; personal protection equipment; regenerable absorbers; chemical oxygen sources;
- test finished products by PRPE manufacturers;
- prolong guaranteed storage life of human respiratory protection devices at warehouses (for example, at warehouses of EMERCOM or oil, gas and coal industry enterprises);
- be applied in medicine for artificial lungs devices;
- fill aqualung cylinders with breathing mixture.

### Originality, uniqueness.

The distinctive feature of this device is ability to implement various breathing pneumotachograms and respiratory quotients that correspond to the different psychophysiological parameters (respiratory rate, breathing depth, type of exercise, etc.).

The peculiar feature of the AL control system is the wide use of mathematical models of individual breathing device to define breath parameters and determine impact of PRPE characteristics, as well as evaluate PRPE quality.

### Specifications.

The device includes a breathing simulator, a simulator of oxygen consumption, carbon dioxide and nitrogen piston dispenser, pipes to connect the individual breathing device, actuators (linear actuators), water bath, cylinders filled with carbon dioxide and nitrogen, flexible tanks filled with carbon dioxide and nitrogen, heater, refrigerator, two- and three-way valves and automated control system.



Device control panel

Chair “Information Systems and Management”, Engineering Centre of Technological Safety, JSC “Corporation” Roskhimzaschita”

Contact person: Doctor of Technical Sciences Pogonin Vasiliy Aleksandrovich

Tel:+7 4752 63-91-87. E-mail: pva@mail.ahp.tstu.ru

## INTELLIGENT DATA-MEASURING SYSTEM FOR NONDESTRUCTIVE TESTING OF THERMO-PHYSICAL PROPERTIES OF SOLIDS

### Designated purpose, application area.

The intelligent data-measuring system (IDMS) is designed for nondestructive testing and research of thermo-physical properties of solids (TPPs) which are used in construction and chemical industry, aviation and energy sector, tool engineering.

Application of intelligent data-measuring system enables to obtain operational and reliable data on thermo-physical properties and to produce materials with the desired properties.

### Originality, uniqueness.

A pilot model of IDMS is developed. It differs from the existing ones by operational features and accurate measurement of TPPs parameters, high metrological level of measurement results, resistance to destabilizing factors due to the measurement method, intelligent probe, knowledge database in the subject area and software.

### Specifications:

range of parameters defined:

- thermal conductivity -  $0.02 \dots 1.00 \text{ W} / (\text{m} \cdot \text{K})$ , thermal diffusivity -  $(1 \dots 10) \times 10^7 \text{ m}^2 / \text{s}$ ;
- dimensions – 280x180x100 mm;
- weight - 2.5 kg;
- temperature range -50 ... +50 °C;
- TPPs parameters definition time - less than 3 minutes;
- measurement error - no more than 3 ... 5%.

### Patent documentation:

• *Certificate of Software Registration No. 2010612526 “Software for Implementation of Functioning Algorithm of Data-Measuring System for Nondestructive Testing of Thermo-Physical Properties of Solids”.* Authors: Samokhvalov A. A., Selivanova Z. M.

• *Patent for the Invention № 2301996 “Method of Nondestructive Testing of Thermo-Physical Properties of Materials and Products”.* Authors: Muromtsev D. Y., Selivanova Z. M.



Chair “Design of Radioelectronic and Microprocessor Systems”

Contact person: Doctor of Technical Sciences Selivanova Zoya Mikhaylovna

Tel: +7 4752 63-00-30. E-mail: selivanova@mail.jesby.tstu.ru



## COMPUTER-AIDED DESIGN SYSTEM FOR CALCULATION OF OPERATING AND DESIGN PARAMETERS OF LATHE PROCESSING

### Designated purpose, application area.

Computer-aided design (CAD) system is used to model and optimize cutting processing of materials. The CAD system can be applied to develop technological processes of metal parts manufacturing for reconstruction and new production on industrial enterprises.

### Originality, uniqueness.

Unlike existing software the developed CAD system provides complete optimization of operating and design parameters of mechanical material processing with regards to power load on cutting tool, stable chip making and vibration resistance of cutting process.

The system provides mathematical modeling of the cutting process, cutting process dynamics research, formulation and solution of operating and designing parameters optimization problem of cutting process.

The system is based on the turning example of core metals and alloys used in industry.

### Patent documentation:

- *Certificate of Software registration No. 2013610309 "Calculation of Mathematical Model Parameters for Cutting Process". Authors: Altunin K. A., Pestretzov S. I., Sokolov M. V., Surkova I. B.*

- *Certificate of Software Registration No. 2013614221 "Analysis of Cutting Process Dynamics". Authors: Altunin K. A., Pestretzov S. I., Sokolov M. V.*

- *Certificate of Software Registration No. 2013617586 "Error Estimation in Lathe Processing". Authors: Altunin K. A., Pestretzov S. I., Sokolov M. V.*

- *Certificate of Database Registration No 2014621741 "Error Estimation in Metal Turning". Authors: Altunin K. A., Pestretzov S. I., Sokolov M. V.*

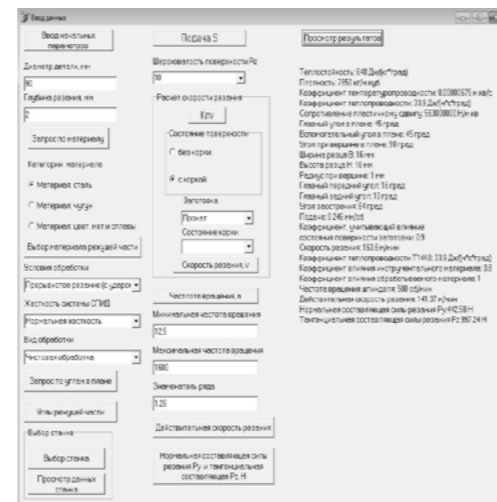
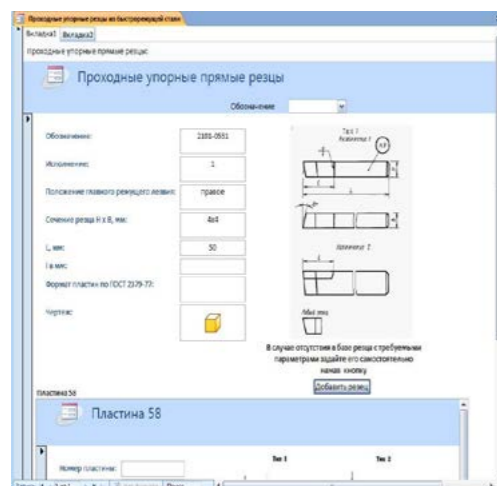
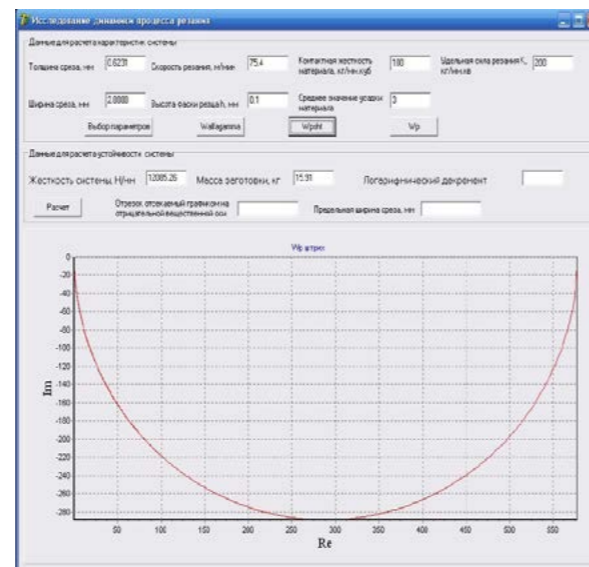

Chair "Computer-Integrated Systems in Mechanical Engineering"  
 Contact person: Doctor of Technical Sciences Sokolov Mikhail Vladimirovich  
 Phone: +7 4752 06-18-63. E-mail: msok68@mail.ru

## VIRTUAL TRAINING SIMULATORS FOR INDUSTRIAL PROCESS OPERATORS

### Designated purpose, application area.

The main purpose of the project is to develop effective tools for industrial enterprise staff training.

### Originality, uniqueness.

Development of virtual training simulators is carried out individually for each technological process taking into account all the specific characteristics of a particular production process.

The mathematical model of human operator activity forms the core of the software, training is held in normal mode of functioning as well as in emergency conditions.

Virtual training complex consists of three main components: virtual training simulator, testing module and interactive 3D-model of an industrial object. Access to the software is carried out remotely. There are two modes of training: autonomous training and training with an instructor.

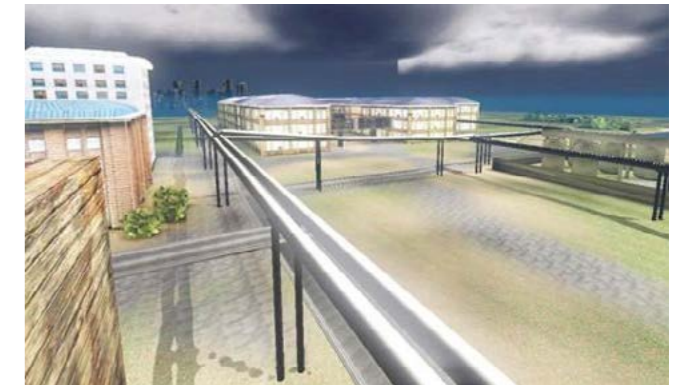

Interactive 3D-Model of an Industrial Object

### Patent documentation:

- *Certificate of Software Registration No. 2010610037 "Virtual Training Simulator for Operators of Chemical and Technological Systems at "TrenHTS". Authors: Krasnyansky M. N., Dedov D. L.*
- *Certificate of Electronic Resource Registration No. 16803 dated 21.03.2011 "3D Component of Virtual Training Simulator for Chemical Engineering Staff Training". Authors: Krasnyansky M. N., Rudnev A. A.*

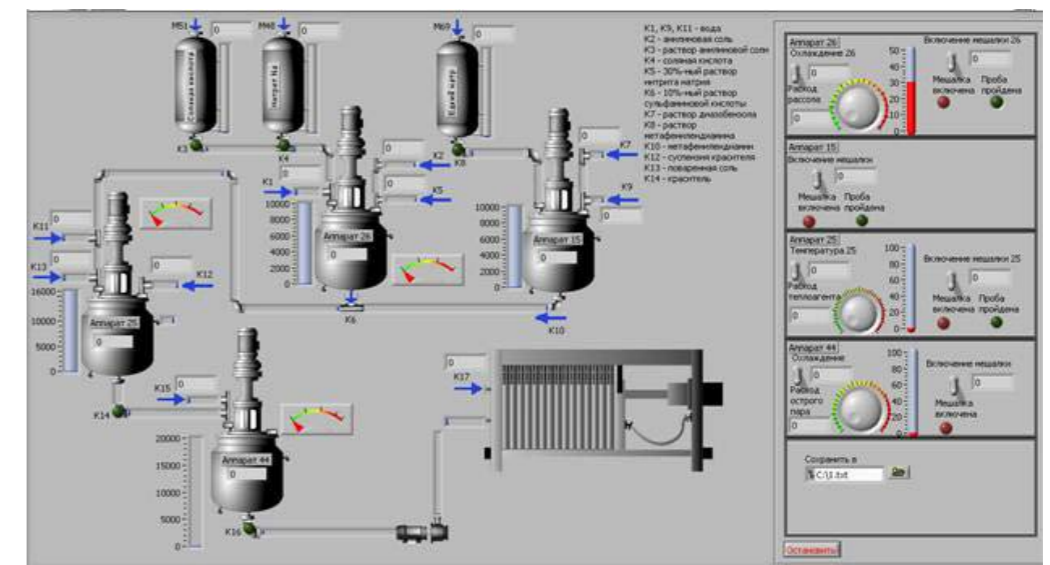

Front panel of virtual training simulator for chemical engineering staff training

Chair "Computer-Integrated Systems in Mechanical Engineering"  
 Contact person: Doctor of Technical Sciences Krasnyansky Mikhail Nikolayevich  
 Phone: +7 4752 10-19-63. E-mail: kras@tambov.ru



## REGIONAL GEO-PORTAL OF CULTURAL AND HISTORICAL HERITAGE

### Designated purpose, application area.

The research teams of the TSTU chairs “Computer-Integrated Systems in Mechanical Engineering” and “Applied Geometry and Computer Graphics” carried out research in the framework of information systems development project «Development of regional Web portal using GIS technologies, methods of retrospective analysis of social-economic and historical processes, spatial and temporal patterns of cultural and historical heritage objects», project No. 11-01-12001v is implemented with the financial support of Russian Humanitarian Scientific Foundation.

All results are focused on the regional history and aimed at shaping the historical memory and continuity of generations and available on the web-site of Tambov State Technical University <http://www.gaps.tstu.ru/grants/index.html>.

### Originality, uniqueness.

The book «Information Technologies for Design of Spatial-Temporal Models of Cultural and Historical Heritage Objects» was published. It presents the results of the development of knowledge base (with remote database access option) containing information on objects of cultural and historical heritage of the Tambov region. An integrated approach was proposed to apply various software environments for modeling objects of the historical heritage. The book provides information of more than 50 objects of cultural and historical heritage of Tambov city and certain administrative units of the Tambov region.

The electronic version of the book is available at <http://www.gaps.tstu.ru/grant/avtr.htm>.

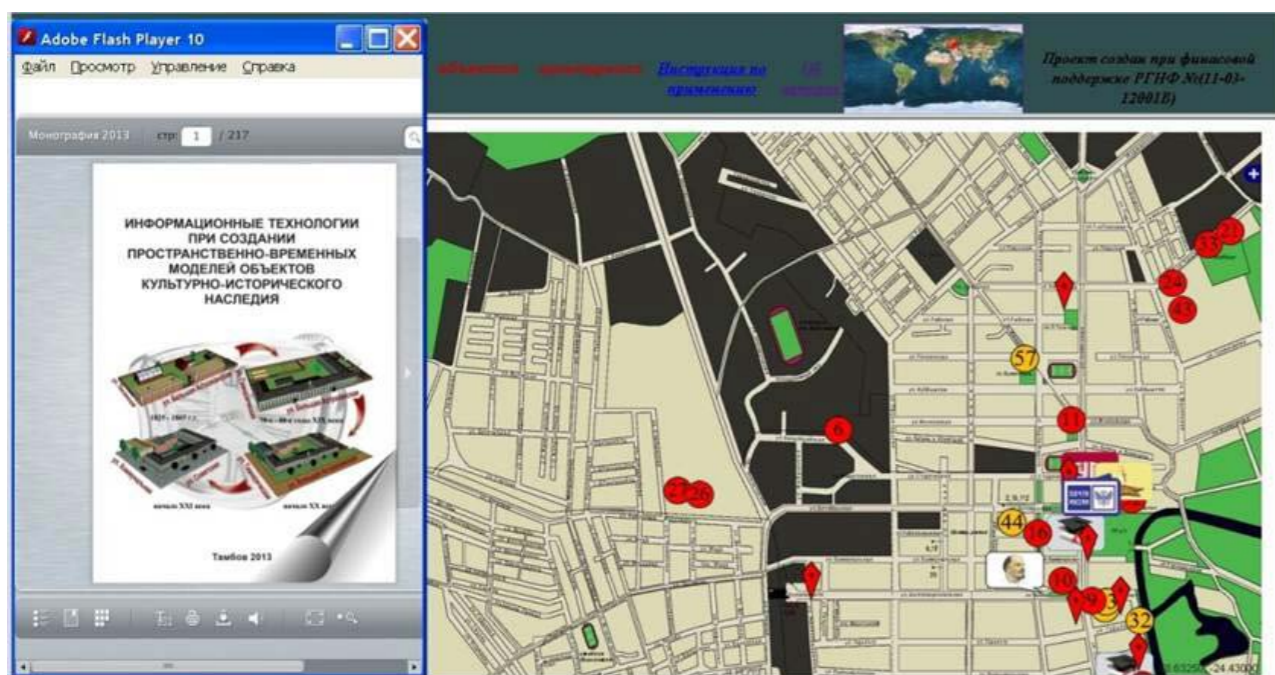

Chair “Computer-Integrated Systems in Mechanical Engineering”  
Contact person: Doctor of Technical Sciences Nemtinov Vladimir Alekseevich  
Phone: +7 4752 63-07-06. E-mail: [nemtinov@mail.gaps.tstu.ru](mailto:nemtinov@mail.gaps.tstu.ru)

## AUTOMATED LABORATORY UNIT FOR RESEARCH OF TECHNOLOGICAL SCHEME FOR NEW CHEMICALS PRODUCTION

### Designated purpose, application area.

Automated laboratory unit (ALU) is designed for research and development of production recipes of large assortment of promising chemicals such as:

- concrete chemical additives (plasticizing agent C3 and superplasticizers, hardening accelerators, antifreeze additives) used in manufacturing of reinforced concrete items, paving slabs, building mixtures and dry mortars;
- formaldehyde resins used for the production of thermal insulation materials (mineral wool, glass wool boards), phenol-formaldehyde and urea-formaldehyde resins for wood processing industries (oriented strand boards);
- sulfamic acid used as detergents and disinfecting agents;
- water-soluble pigments.

### Originality, uniqueness.

ALU enables to develop different technologies of chemicals and intermediate products manufacturing, to organize various technological schemes by reconfiguring the system components (loading tanks, pumps, reactors, thermostats).

ALU control system provides:

- different temperature regimes of the process in reactors (heating, cooling, temperature stabilization,

program control);

- various modes for reagents dosing in accordance with the technological cards (dosing by weight, dosing by predetermined or variable performance according to the programme configuration, dosing for achievement of a given pH value, etc.);
- different hydrodynamic modes of the process in reactors due to the wide range of stirrer rotation frequency;
- recording of the process progress (recording of technological parameters trends in graphical and tabular forms, archiving, logging operator actions).

### Specifications.

The laboratory unit includes three reactors with a jacket and a stirrer, six tanks installed on the scale, seven metering pumps and three thermostats. The reactors are designed to monitor pH, ambient temperature, coolant temperature, stirrer speed. Loading containers used for dosing of raw materials and semi-products using metering pumps. The thermostats are designed to implement temperature modes automatically.



Laboratory unit

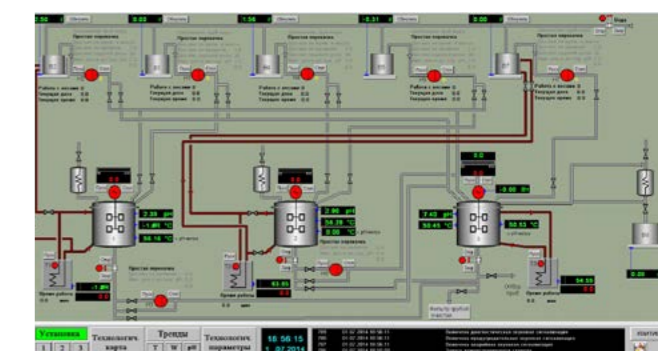

Operator's automated workstation

Chair “Information Processes and Management”, Engineering Center of Technological Safety, JSC “Pigment”  
Contact person: Candidate of Technical Sciences Elizarov Igor Aleksandrovich  
Phone: +7 4752 63-91-87. E-mail: [elial68@yandex.ru](mailto:elial68@yandex.ru)



## VIRTUAL ROOM “DESIGN OF TECHNOLOGICAL EQUIPMENT”

### Designated purpose, application area.

The virtual room “Design of Technological Equipment” is a system of automated information system components designed for students studying courses of technological equipment structure, methods of equipment calculation and design.

The virtual room includes computer programmes and information resources that can be accessed over the Internet and local area network (including exclusive use).

Virtual room web-site: [www.gaps.tstu.ru/kir](http://www.gaps.tstu.ru/kir).

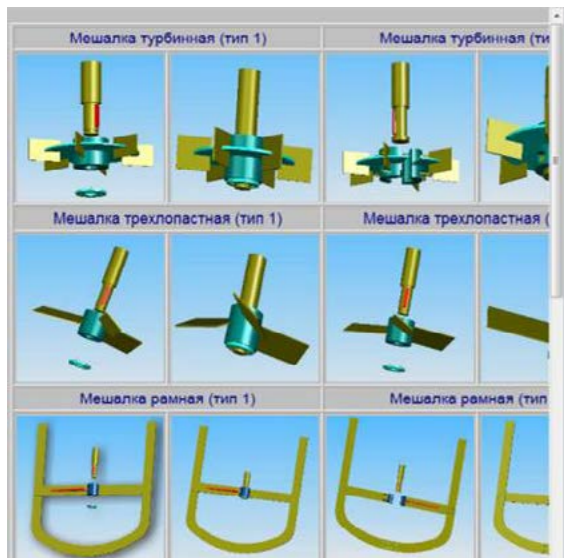

The example of 3D model of vessels stirrers

The modules of the local network are intended for enterprises designing technological equipment as well as to train students within the university or department local area network.

### Originality, uniqueness.

The virtual room allows:

- to carry out mechanical calculations of technological equipment;
- to choose the sizes of individual elements of

technological equipment;

- to obtain reference data necessary for equipment design (mechanical properties of materials, corrosion resistance, types of welds, etc.);
- to get acquainted with 3D model of typical equipment elements. Modern graphical tools allow to create 3D models of components and assemblies that are close to the real ones;
- to design technological schemes.

### Patent documentation:

- The Certificate of Software Registration No. 2010610139 “Virtual Room for Technological Equipment Design. Version 2”. Authors: Mokrozub V. G., Belikov A. I., Cherepakhina S. V., Lukonov D. A.



The main page of the web-site - [www.gaps.tstu.ru/kir](http://www.gaps.tstu.ru/kir)

### Chair “Computer-Integrated Systems in Mechanical Engineering”

Contact person: Candidate of Technical Sciences Mokrozub Vladimir Grigoryevich

Phone: +7 4752 63-07-06. E-mail: [mokr@mail.gaps.tstu.ru](mailto:mokr@mail.gaps.tstu.ru)

## SOFTWARE PACKAGE FOR CALCULATION OF THERMAL CONDUCTIVITY COEFFICIENT OF BUILDING MATERIALS CONTAINING HYGROSCOPIC SALTS

### Designated purpose, application area.

The software package is designed to calculate thermal conductivity coefficient of building materials (papercrete, mineral wool slabs, sand-lime and ceramic bricks) that contain hygroscopic salts.

### Originality, uniqueness.

The uniqueness of the software package is that thermal conductivity coefficients of building materials are calculated not only depending on the amount of moisture and salts of different chemical and phase composition but also depending on the type of crystal lattice of salts (anhydrous salt or crystal hydrates). It differs from analogues by registering of volumes of pore space filled with salts depending on the temperature. The software is written in C ++.

The output data of the software contains calculation results of volumes of pore space filled with solid, liquid and gas phase of constituents of inner pore substance (salt crystals, solutions and steam) and coefficients of its thermal conductivity and thermal conductivity of salt-permeated material.

Developed software package allowed to get new data on the effect of inorganic salts on the thermal conductivity of dry and moist materials with different density and porosity and to propose a classification of salts by groups for registration of their influence on the thermal conductivity of the wall materials through correction coefficients.

### Patent documentation:

- The Certificates of Software Registration No 2013618074, 2013661760, 2013660377, 2013661687

Foamed silicate thermal conductivity,  $W / (m^2 \cdot C)$  depending on the specific salinity and moisture content ( $\omega$ ) with different:

a - density;

b - thermal conductivity of crystals;

c - solubility;

d - hygroscopic property

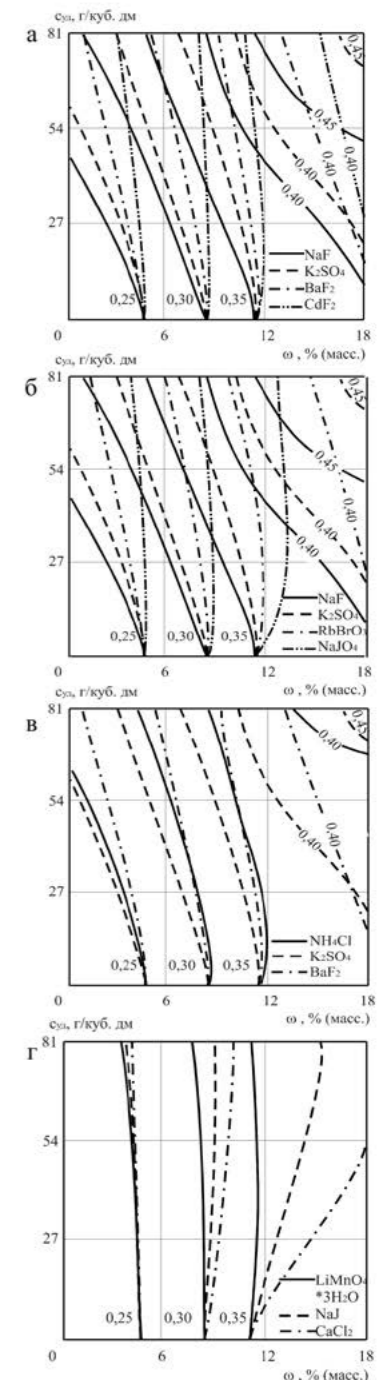

### Chair “Architecture and Building Construction”

Contact person: Candidate of Technical Sciences Elchischeva Tatyana Fedorovna

Phone: +7 4752 63-93-73. E-mail: [elschevat@mail.ru](mailto:elschevat@mail.ru)



## VIRTUAL MODEL PROTOTYPE OF CHEMICAL TECHNOLOGY UNIVERSITY HARDWARE

### Designated purpose, application area.

Virtual model of hardware is a system of mathematical tools, software and hardware designed to study and develop industrial objects, organize objects management.

Components of the virtual model of the Chair “Computer-Integrated Systems in Mechanical Engineering” hardware:

- laboratory for 3D modeling of technological equipment components and units;
- laboratory for virtual simulation of industrial equipment and technological systems;
- laboratory for technological systems simulation;
- laboratory for virtual simulators to train chemical and technological system operators;
- laboratory of virtual models of geographically-distributed objects;
- virtual room “Design of Technological Equipment”.

### Originality, uniqueness.

The advantages of the chair teaching resources virtual model are:

- training costs reduction (reduction of rental expenses and travel costs to the place of study);
- education quality improvement due to the use of modern technical means and electronic libraries.



Part of virtual model circuit of the Chair «Computer-Integrated Systems»(TSTU) hardware

### Patent documentation:

- *Virtual Room for Technological Equipment Design. Version 2. Certificate of Software Registration No. 2010610139.*
- *Calculations of Chemical Equipment Mechanical Elements Version 2. Certificate of Software Registration No. 2010610136.*
- *System of Restrictions Formation and Control for Technological Systems Layout. Certificate of Software Registration No. 2014613415.*

**Chair “Computer-Integrated Systems in Mechanical Engineering”**  
 Contact person: Doctor of Technical Sciences Nemtinov Vladimir Alekseevich  
 Phone: + 4752 63-07-06. E-mail: nemtinov@mail.gaps.tstu.ru

## AUTOMATED INFORMATION SYSTEM «CHILDREN’S HEALTH»

### Designated purpose, application area.

Automated Information System (AIS) for monitoring of schoolchildren’s health is set up in 104 municipal educational institutions of the Tambov region. AIS main functions are:

- automated collection and automatic expert assessment of medical examinations data, physical fitness tests, acute and chronic diseases of schoolchildren;
- health monitoring electronic document management systems between schools and health authorities;
- information of the regional statistical reporting on the state of schoolchildren’s health taking into account different administrative-territorial and the age-sex criteria;
- increasing the level of schoolchildren’s health by improving the quality of decision-making process.

### Originality, uniqueness.

Most modern systems for children’s health monitoring, making an integral assessment of health are designed to automate the activities of medical institutions specialists. Such systems are not normally used for schoolchildren’s health monitoring in schools. But foreign children’s health monitoring systems are designed to get generalized statistics. Such systems

provide data on the state of society development and social trend rather than medical. AIS enables the assessment of an individual child’s health during the education period and monitor the dynamics of children’s health indicators.

### System advantages:

- formation of statistical reporting taking into account different administrative-territorial and the age-sex criteria;
- electronic document management system;
- easy data exchange process;
- operation in network and local modes;
- availability of training mode.

### AIS consists of the following subsystems:

- the subsystem “School” is designed for school nurse work implementation;
- the subsystem “Health Care” provides a view of the data on the health of children throughout the region;
- the subsystem “Administrator” is intended to edit all system directories and users’ access.



Subsystem “School” – medical examination form

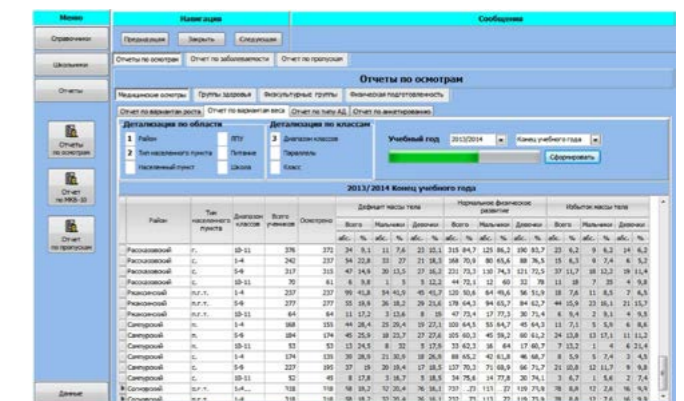

Subsystem “Health care” – regional statistical reporting

**Chair “Biomedical Engineering”**  
 Contact person: Doctor of Technical Sciences Frolov Sergey Vladimirovich  
 Phone: +7 4752 63-56-20. E-mail: sergej.frolov@gmail.com

## CARDIOVASCULAR HEMODYNAMICS SIMULATION SYSTEM

### Designated purpose, application area.

Cardiovascular diseases are the leading cause of death. Mathematical models of cardiovascular systems hemodynamics are applied for diagnosis and treatment planning of such diseases in decision support systems. The Chair «Biomedical Engineering» of TSTU together with A.N. Bakoulev Research Center for Cardiovascular Surgery have developed a software package for overall hemodynamics modeling in diagnosis and treatment of blood circulation disorders.

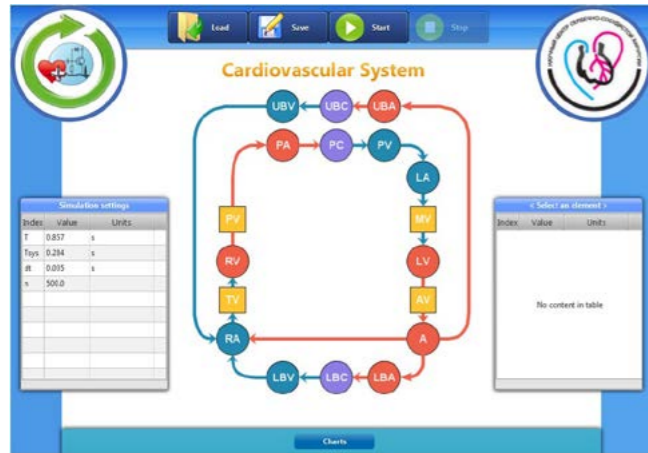

Main window of the system



Example of aorta hemodynamic function calculation

### Originality, uniqueness.

The software package is based on original mathematical model of blood circulation, it is intended for calculation of the following hemodynamics functions: pressure, volume, speed of blood flow. It provides carrying out virtual experiments to plan and analyze ways of treatment without harm to the patient's health, helps surgeons identify various factors affecting the result of operations, predict the cause and development of cardiovascular diseases.

### Application Area:

- medical diagnostics - cardiovascular diseases such as atherosclerosis and cerebral aneurysm are associated with hemodynamics;
- development of prosthetic devices, stents, etc.;
- planning and optimization of operations-change of hemodynamic parameters after operations can have negative consequences and result in heart failure;
- training of surgeons and anesthetists -cardiovascular system simulator can be used for training.

### Patent documentation:

- *Certificate of Software Registration No. 2013618070 «Cardiovascular Hemodynamics Simulation System». Authors: Frolov S. V., Sindeev S. V., Lishchuk V. A., Gazizova D. S.*
- *Certificate of Software Registration No. 2014615162. "Basic Model of Cardiovascular System for Simulation Research in Intensive Care." Authors: Frolov S. V., Sindeev S. V., Lishchuk V. A., Gazizova D. S.*

### Chair "Biomedical Engineering"

Contact person: Doctor of Technical Sciences Frolov Sergey Vladimirovich

Phone: +7 4752 63-56-20. E-mail: sergej.frolov@gmail.com

# Mechanics and Mechanical Engineering



## USE OF ORDERED INGREDIENTS LOADING FOR THE PRODUCTION OF HIGH-GRADE MIXTURE OF BULK MATERIALS

### Designated purpose, application area.

In chemical and related industries circulation mixers are widely used. Requirements to quality of bulk materials are rather high because of nanotechnologies development. At the same time the content of nanomaterials in the total volume of mixture is low.

### Originality, uniqueness.

Bulk materials in the process of mixing differ by particles size and/or density, so segregation of smallest and/or heavy particles negatively affect the finished mixture quality. One of the most effective methods is loading of mixture ingredients into circulation mixer, it's necessary to take into consideration all specific combinations of bulk materials ingredients. In this case segregation can promote the production of high quality mixtures. It's because of ordered type of ingredients movement in circulation mixers and the zones of segregation state of mixture are easily predictable.

To calculate the process the mathematical model of mixing bulk materials in drum continuous mixers is used. The use of such model results in numerical experiments aimed at calculations of process organization which ensures high quality of finished mixture.

New constructions of bulk materials mixers with regulated ingredients loading are patented and tested. Such constructions are used for continuous production of compound mixtures.

### Patent documentation:

- *Certificate of Software Registration № 2002612031 "Optimization of Bulk Materials Mixing Process in Drum Continuous Mixers (Mixing in Drum Mixer)". Authors: Selivanov Yu. T., Pershin V. F., Orlov A. V.*
- *Certificate № 1599073 (USSR) "Drum Mixer for Bulk Materials". Authors: Pershin V. F., Selivanov Yu. T., Tkachev A. G., Tokarev V. I., Suvorov A. V.*
- *Patent № 2207900 "Method of Continuous Preparation of Compound Mixtures and Device for Realization". Authors: Selivanov Yu. T., Pershin V. F., Orlov A. V.*
- *Patent № 2478420 "Method of Continuous Preparation of Compound Mixtures and Device for Realization». Authors: Selivanov Yu. T., Pershin V. F., Durnev A. S.*

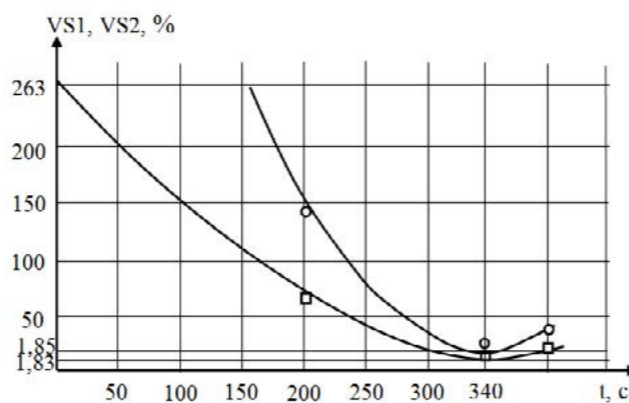

Change of qualitative mixture composition in case of continuous loading of main ingredients along the drum (the best quality of final mixture regarding both key ingredients is achieved simultaneously, heterogeneity coefficient VS1, VS2, %, of each main ingredient does not exceed 1,85%)

## SCREW MIXER WITH PADDLE WORKING BODIES

### Designated purpose, application area.

The device is designed to produce dry feedstuff for livestock according to zootechnic requirements.

### Originality, uniqueness.

Time for portion preparation is reduced because of ordered movement of foodstuff ingredients inside the mixer. This device is a low-speed mixer with periodic motion with two paddle working bodies.

### Specifications:

- portion size – 0,33 m<sup>3</sup>;
- capacity is up to 3 t/h;
- installed capacity – 4,4 kWatt;
- rotation frequency of working bodies – 0,85 s<sup>-1</sup>;
- mixer mass – 420 kg;
- overall size- 2700x1060x1710 mm.

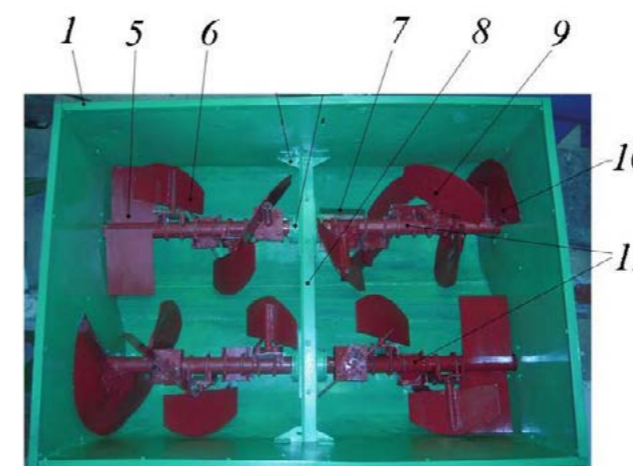

Mixer construction:

- 1 – hopper; 5 – throw blades; 6, 7, 9 – mixing-transporting blades; 8 – spacer; 10 – auger winding; 11 – shafts of working bodies.

### Patent documentation:

- *Patent № 2381725 "Feedstuff Mixer". Authors: Vedishchev S. M., Sviridov M. M., Prokhorov A. V., Usatyuk N. V., Samoilo E. A., Kholshchev N. V.*



## HIGH-SPEED PLANETARY MILL

### Designated purpose, application area.

One of the most perspective ways to produce nanomaterials is grinding in planetary ball mill, since this way may be realized in industrial scale. Besides, new materials can be produced by means of mechanical alloying in planetary mills, it is the only way to get such materials. Currently centrifugal acceleration in the grinding zone even in laboratory mills is not more than 80g.

### Originality, uniqueness.

Developed mill produces acceleration up to 500g. Testing results prove that significant increase of congestion in grinding zone not only ten times reduces the milling time, but also allows to get new results, in particular to reduce the number of graphene layers.

New pilot plant with calculated acceleration 1500g is designed and produced in cooperation with JSC "Komsomolets" named after N. S. Artemov. Currently commissioning works are carried out.

The perspectives of high-speed planetary mill using are:

- reduction of graphene nanostructures layers number in additives to lubricants;
- mechanical activation of flasks while creating sorbents modified by carbon nanomaterials;
- glass grinding for foamed glass production.



High-speed planetary mill operation

Chair "Engineering Mechanics and Machine Parts", Research Laboratory "Mechanics of Bulk Materials"  
 Contact person: Doctor of Technical Sciences Pershin Vladimir Federovich  
 Tel: +7 910 652-53-77. E-mail: pershin.home@mail.ru

## ORDERED MIXING OF BULK MATERIALS IN PADDLE MIXER

### Designated purpose, application area.

Developments are related to the bulk materials processing field, in particular the processes of preparation of multicomponent mixtures with guaranteed and predictable quality in mixers with internal working parts. They are used in chemical, construction, food, pharmaceutical industries and agriculture.

### Originality, uniqueness.

Distinctive feature of developments is a complex approach to problem solution of bulk materials mixing of required quality. Organization of mixture preparation ordered process is provided and then the operational control of the finished mixture to check the mixing process is guaranteed.

The mixing process is carried out in the paddle mixer original constructions.

High predicted quality of mixture preparation is provided by the intensification of various mixing process periods due to the directional change of particle fluxes of bulk materials inside the reaction chamber of the mixer, that allows reducing the process energy losses, dynamic loads on the working



Paddle mixer (exterior)

parts and drive shaft, considering the characteristics of their work, reducing the coefficient of the mixture inhomogeneity, optimizing the number and location of the blades, etc. The implementation of constructive changes in the paddle mixer and corresponding mixing process is simple, low cost and universally applicable.

Quality control is carried out immediately after the mixing process with the help of the special device by comparison the surface image of ready mixture with the "example" image or by definition of the inhomogeneity coefficient based on the image analysis. If any deviations from the predetermined values are detected, the measures of the rapid change of paddle mixer parameters are taken.

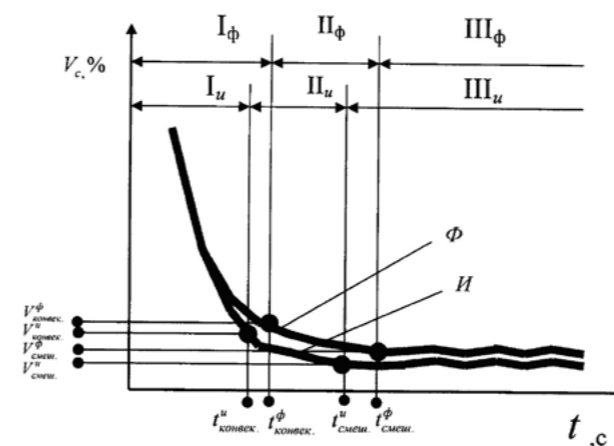

Kinetic curves of the mixing process with fixed (curve  $\Phi$ ) and variable (curve  $\Pi$ ) locations of working parts

Department "Engineering Mechanics and Machine Parts"  
 Contact person: Candidate of Technical Sciences Demin Oleg Vladimirovich  
 Tel.: +7 4752 60-18-01. E-mail: oleg\_demin\_78@mail.ru



## DEVICE FOR REDUCTION OF DIESEL ENGINES EMISSIONS TOXICITY

### Designated purpose, application area.

The device is designed to reduce the exhaust emissions of diesel engines with capacity of 150 ... 220 kW.

### Originality, uniqueness.

It differs from analogues by three levels of purification: filter sump, electric afterburner of non-condensed gases and catalyst.

The scheme of the combined device is shown below.

**Specifications.** The device is installed instead of silencer. Reactor diameter - 0,118 m, height of the reactor - 0.144 m. Diameter of catalyst pellets - 8 mm.

The toxicity of engine exhaust gases with a combined device meets the standards of Euro-5. This reduces the pressure of the exhaust gases by 2.4%, the temperature is increased by 5.5% and the fuel consumption - by 1.1%.

### Patent documentation:

- Patent № 2010143617/06 "Combined Device for Reduction of Diesel Emissions Toxicity". Authors: Chernetsov D.A., Kapustin V.P., Goncharov A.V

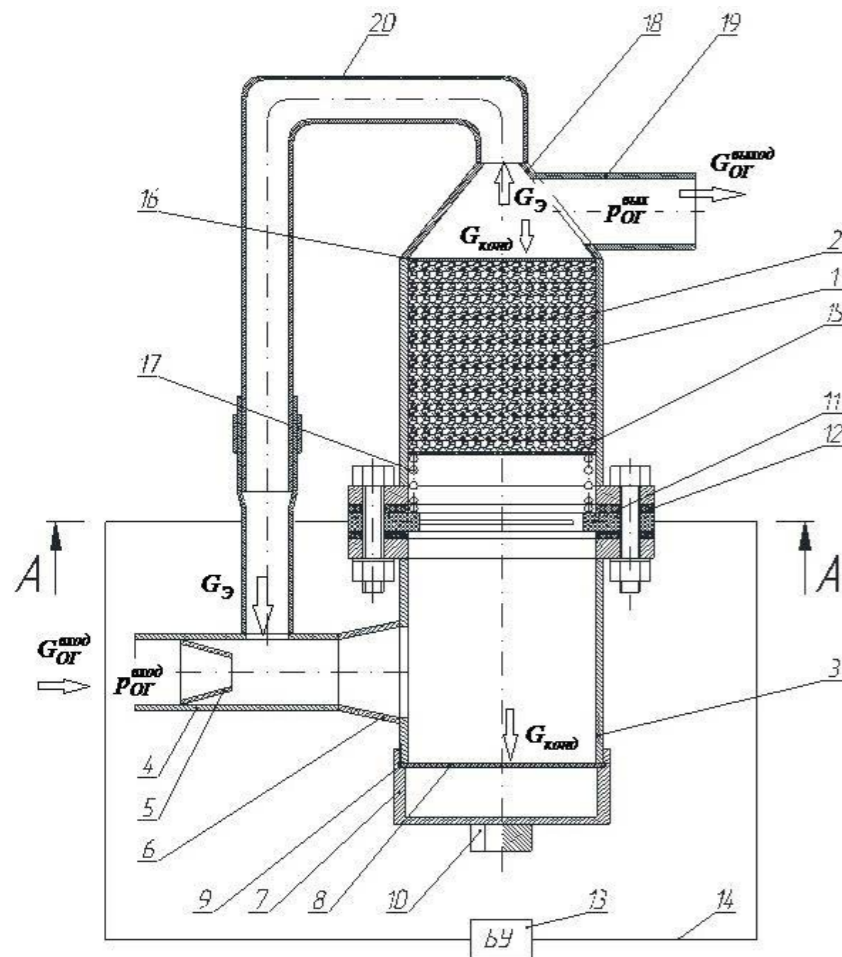

- 1 - catalyst layer (reactor);
- 2 - upper part of frame;
- 3 - lower part of frame;
- 4 - branch pipe;
- 5 - ejector;
- 6 - diffuser;
- 7 - filter sump;
- 8 - metal grid;
- 9 - gasket;
- 10 - screw;
- 11 - electric spiral;
- 12 - sealing gaskets;
- 13 - control module;
- 14 - electric wires;
- 15 - front grille;
- 16 - output grille;
- 17 - bimetallic coil spring;
- 18 - confuser;
- 19 - outlet pipe;
- 20 - T-shaped pipe.

Department "Agricultural Engineering"  
 Contact person: Candidate of Technical Sciences Kapustin Vasilij Petrovich  
 Tel.: +7 4752 63-57-94. E-mail: msh@nnn.tstu.ru

## SERIES OF AUTOMATICALLY ADJUSTABLE FLOW DIVIDERS OF BULK MATERIALS

### Designated purpose, application area.

Automatically adjustable flow dividers of bulk materials are used for separation of falling streams of bulk materials to the equal parts or at predetermined ratio, in particular in multichannel technologies of grain processing.

### Originality, uniqueness.

Dividers provide the broad field of automatic regulation and accuracy of bulk materials flow separation in the range of 1...3% divergence of mass expenditures.

### Specifications.

Flow range shared stream 10...120 t/h, number of withdrawn flows - not limited.

### Patent documentation:

- Originality of the unit is confirmed by 9 RF Patents № 2341954, 2412582, 2437271, 2455817, 2459405, 2490863, 2520341, 2525728, 2540352.



Vertical divider



Automatically adjustable flow dividers

Chair "Agricultural Engineering", "All-Russian Research Institute of Technology and Use of Petroleum Products in Agriculture"  
 Contact person: Doctor of Technical Sciences Tishaninov Nikolay Petrovich  
 Tel: +7 4752 44-21-54. E-mail: agroeffekt@mail.ru

## MODELING OF INTELLIGENT THIN-WALLED CONSTRUCTIONS WITH PIEZOELECTRIC SENSORS AND ACTUATORS BASED ON GEOMETRICALLY EXACT FINITE SHELL ELEMENTS

**Designated purpose, application area.**

Application area for developed software package is aviation, missilery and space engineering. Built finite element code can be used in controllers of intelligent thin-walled composite structures used for various purposes.

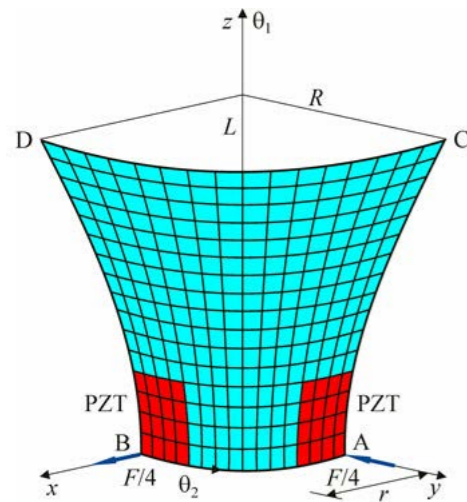

**Originality, uniqueness.**

Results received are new. There are no analogues for results comparison as before the similar problems were solved by ineffective isoparametric finite shell elements. The developed software package allows to find the optimal voltages applied to the electrodes of the piezoelectric elements in order to absorb vibrations that may arise during the operation of thin-walled structures. The basis of the numerical algorithm is the model of a layered piezoelectric membrane based on counting surfaces, which allows to consider spatial distribution of stress and strain fields.

New geometrically exact four-node shell finite elements with independent approximations of displacements, strains, stresses and the resulting electrical potential to overcome the shear and membrane locking sheath are designed.

**Patent documentation:**

- *Certificate of Software Registration № 2013618597 "Program TMS3DEMOC to Solve the Problem of Vibrations Control of Thin-Walled Adaptive Structures Made of Composite Laminates Subjected to Electromechanical Stress, Based on Geometrically Exact Finite Elements". Authors: Kulikov G. M., Plotnikova S. V.*

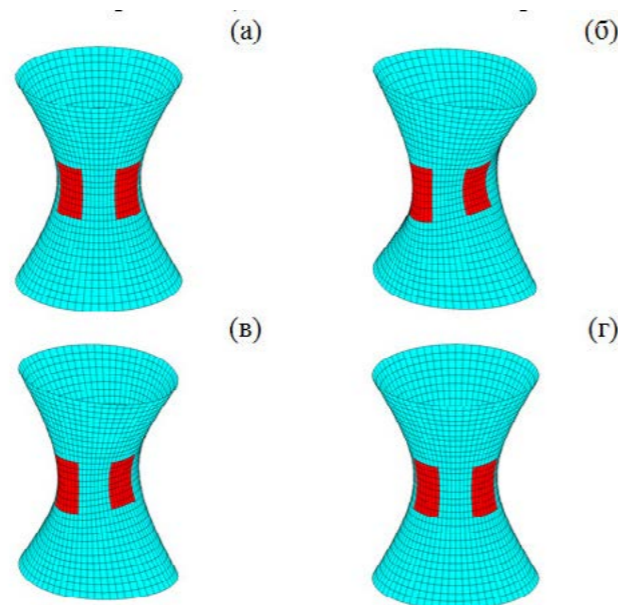

*Control of three-layer carbon fiber hyperbolic shell shape [90°/0°/90°] with four piezoelectric strips PZT with the action of two tensile and two compressive forces of F value in the central part by applying voltage f, applied to the electrodes:*

- a -  $F = 0, f = 0;$
- б -  $F = 200 H, f = 0;$
- в -  $F = 200 H, f = 1000 B;$
- г -  $F = 200 H, f = 1960 B$

Chair "Applied Mathematics and Mechanics"

Contact person: Doctor of Physics and Mathematics Kulikov Gennady Mikhailovich

Tel: +7 4752 63-03-67. E-mail: kulikov@apmath.tstu.ru





Tambov State Technical University



**392000, Russian Federation, Tambov, Sovetskaya str., 106**  
**+7-4752-63-10-19, fax: 63-06-43**  
**tstu@admin.tstu.ru**

**Vice Rector for Science:**  
**prof. Dmitry Muromtsev**  
**+7-4752-63-92-82**  
**nauka@tstu.ru**

*This Catalogue is available at:*  
*<http://dn.tstu.ru/index.php/catalog>*